



**Goa Natural Gas Pvt Ltd.
(A JV of GAIL GAS LIMITED & BPCL)
Plot No. 33 Rajan Villa, Journalist Colony, Porvorim, Goa.
Pin-403521**

**Tender Document for
Hiring of Operations & Maintenance Services for City
Gas Distribution Project of GNGPL in North Goa GA**

**Tender No. GNGPL/C&P/T-34
OPEN DOMESTIC COMPETITIVE BID**

TABLE OF CONTENTS

SR. NO.	SECTION NUMBER	DESCRIPTION	PAGE NO.
1	SECTION-I	INVITATION FOR BID (IFB)	3 TO 5
2	SECTION-II	INSTRUCTION TO BIDDERS (ITB) PART-1: BEC AND AWARD METHODOLOGY PART-2: OTHER INSTRUCTION TO BIDDERS	6 TO 35
3	SECTION-III	SPECIAL CONDITIONS OF CONTRACT (SCC)	36 TO 113
4	SECTION-IV	GENERAL CONDITIONS OF CONTRACT (GCC)	114 TO 114
5	SECTION-V	FORMS AND FORMAT	115 TO 164
6	SECTION-VI	SCHEDULE OF RATE	164 TO 177

GCC:

GENERAL CONDITIONS OF CONTRACT (GCC) IS AVAILABLE AT OFFICE OF GNGPL AND/OR ON WEBSITE ALSO. GCC SHALL BE PART OF THIS TENDER. BIDDER SHALL READ, UNDERSTAND AND ACCEPT THE TERMS AND CONDITIONS OF GCC BEFORE SUBMITTING THE BID. ANY BIDDER WHO HAS SUBMITTED THE BID SHALL BE DEEMED THAT HE/HER/COMPANY HAS READ, UNDERSTOOD AND ACCEPTED THE TERMS AND CONDITIONS OF GCC.

SECTION-I
INVITATION FOR BID (IFB)

SECTION-I
"INVITATION FOR BID (IFB)"

Ref No: GNGPL/C&P/T-34

Date: 15/02/2022

To,
PROSPECTIVE BIDDERS,

SUB: Hiring of Operations & Maintenance Services for City Gas Distribution Project of GNGPL in North Goa GA

Dear Sir/Madam,

1.0 GNGPL, a JV of GAIL GAS LTD and BPCL is engaged in development of City Gas Distribution Networks (CGDN) at Geographical Areas of North Goa and Ponda for distribution of CNG and PNG to various consumer segments, invites bids from domestic bidders for the subject job/works, in complete accordance with the following details and enclosed Tender Documents.

2.0 **The brief details of the tender are as under: -**

A	NAME OF WORK/BRIEF SCOPE OF WORK/JOB	HIRING OF OPERATIONS & MAINTENANCE SERVICES FOR CITY GAS DISTRIBUTION PROJECT OF GNGPL IN NORTH GOA GA
B	TENDER NO. AND DATE	GNGPL/C&P/T-34 DATED 15/02/2022
C	TYPE OF BIDDING SYSTEM	TWO PART BID SYSTEM (2 ENVELOPE)
D	TYPE OF TENDER	OPEN DOMESTIC TENDERING
E	COMPLETION/CONTRACT PERIOD	ONE YEAR FROM THE DATE OF NOTIFICATION OF AWARD. NOTE: - Contract can be further extended to another one year based on the requirement on sole discretion of GNGPL on same rate, terms and conditions
F	TENDER FEE	NOT-APPLICABLE
G	BID SECURITY/EARNEST MONEY DEPOSIT (EMD)	APPLICABLE AMOUNT: RS. 3,89,438/- (REFER CLAUSE NO.16 OF ITB)
H	DATE, TIME AND VENUE OF PRE-BID MEETING	DATE: - 23/02/2022 TIME: - 15.00 HRS Due to outbreak of Covid-19, Pre-Bid meeting shall be conducted through Video Conferencing (Bidders who are interested to attend the meeting, please send the request for the same to the e-mail id contracts@goanaturalgas.com of to get the link)
I	DUE DATE AND TIME OF BID SUBMISSION	DATE: - 07/03/2022 TIME: - 15.00 HRS AT GNGPL OFFICE
J	DATE AND TIME OF UN-PRICED BID OPENING	DATE: - 07/03/2022 TIME: - 16.00 HRS AT GNGPL OFFICE
K	CONTACT DETAILS	Mr. Nilesh Nagawade (Senior Manager, CGD) Goa Natural Gas (P) Ltd Plot No.33, Rajan Villa, Journalist Colony, Porvorim-Goa,403521 Email Id: - contracts@goanaturalgas.com

In case of the days specified above happens to be a holiday in GNGPL, the next working day shall be implied.

- 3.0 Bids must be submitted strictly in accordance with Clause No. 11 of ITB depending upon Type of Tender as mentioned at Clause no. 2.0 (D) of IFB. The IFB is an integral and inseparable part of the bidding document.
- i) Demand Draft towards Tender fee (if applicable)
 - ii) EMD/Bid Security (if applicable)
 - iii) Power of Attorney
 - iv) Integrity Pact (if applicable)
- 4.0 In case of Manual Bids, bids complete in all respect should reach at the address specified in IFB on or before the due date & time. Bids received after the due date and time is liable to be rejected.
- 5.0 Bidder(s) are advised to quote strictly as per terms and conditions of the tender documents and not to stipulate any deviations/exceptions.
- 6.0 Any bidder, who meets the Bid Evaluation Criteria (BEC) and wishes to quote against this tender, may download the complete bidding document along with its amendment(s) if any from website www.goanaturalgas.com / www.eprocure.gov.in and **submit (offline)** (address specified in clause no. 2.0 (K) of IFB) their Bid complete in all respect as per terms & conditions of Tender Document on or before the due date of bid submission.
- 7.0 Clarification(s)/Corrigendum(s), if any shall also be available on above referred websites and/or will be sent on address/E-mail of prospective bidders/available at GNGPL office.
- 8.0 All the bidders including those who are willing/not willing to submit their bid are required to submit F-11 (Acknowledgement cum Consent letter) duly filled within 7 days from receipt of tender information.
- 9.0 GNGPL reserves the right to reject any or all the bids received at its discretion without assigning any reason whatsoever.

This is not an Order.

FOR & ON BEHALF OF GNGPL

**M. Z. KHAN
(CHIEF EXECUTIVE OFFICER)**

SECTION-II

INSTRUCTIONS TO BIDDERS (ITB)

CONTENT OF SECTION-II:

- 1. PART-1: BEC AND AWARD METHODOLOGY**
- 2. PART-2: OTHER INSTRUCTIONS TO BIDDERS**

SECTION-II
PART-1: BEC AND AWARD METHODOLOGY

A) TECHNICAL:

1. The bidder should have executed at-least one (01) single order / contract, having minimum value of **INR 43.41 Lakhs** providing O&M services to any CGD company in previous seven (07) years to be reckoned from the bid due date

AND

2. The bidder must have experience in the field of MDPE laying/Carbon Steel pipeline laying/Above ground GI infrastructure development work (LMC) in previous seven (07) years to be reckoned from the bid due date.

NOTE: -

- a) In case, a bidder is executing a contract as mentioned above which is still running, the contract value executed till one day prior to due date of bid submission should be equal to or more than the minimum prescribed value mentioned at clause A-1 above. such experience will also be taken into consideration provided that the bidder has submitted satisfactory work execution certificate issued by the end user / owner / authorized consultant.
- b) A job executed by a bidder for its own plant/projects cannot be considered as experience for the purpose of meeting requirement of BEC of the tender. However, jobs executed for a subsidiary / Fellow Subsidiary / Holding company will be considered as experience for the purpose of meeting BEC subject to submission of Tax paid invoice (s) duly certified by Statutory Auditor of the bidder towards payment of Statutory tax in support of the job executed for subsidiary/Fellow subsidiary/Holding company. Such bidders to submit these documents in addition to the documents specified in the bidding documents to meet BEC
- c) In case, the contract considered for above clause A-1 has an SOR which contains MDPE Laying/ Steel Pipeline laying/Above ground GI infrastructure development (LMC) then such bidders shall also be qualified.

B) FINANCIAL:

1. Annual Turnover

The minimum annual turnover achieved by the bidder as per their audited financial results in any one of the last three (3) preceding financial years i.e., FY 2018-19, FY 2019-20 & FY 2020-21 shall be **INR 144.71 Lakhs**

2. Net Worth

Net worth of the bidder should be **positive** as per the immediately preceding year's audited financial results i.e., in FY 2020-21.

3. Working Capital

The minimum working capital of the bidder as per the immediately preceding year's audited financial results i.e., in FY 2020-21 shall be **INR 28.94 Lakhs**

- If the bidder's working capital is inadequate or negative, the bidder should furnish a letter from the Bidder's bank (as per format in tender document) having net worth not less than Rs 100 Crore, confirming the availability of the line of credit for at least for the working capital requirement as stated above.

C) The documents required to be submitted by the bidder to substantiate their qualification under Bidder Evaluation Criteria (BEC) shall be as follows:

BEC Clause no.	Description	Documents required for qualification
Technical BEC		
A.1 & A.2	Technical BEC	<p>For Experience against execution & completion of order: - Bidder must submit/upload:</p> <p>a) Copy of Order/LOA/Contract along with its detail SOR items & scope of work which has been executed towards similar nature of jobs as mentioned at BEC A-(1 & 2) in previous seven (07) years to be reckoned from the due date of bid opening.</p> <p>b) Copy of Completion Certificate or equivalent against the Order/LOA/Contract submitted as mentioned at point "a" above, must be submitted. The Completion Certificate or equivalent must contain the detailed information like Order/LOA/ Contract No. with date, Brief Scope of work / Name of work, Order value, Total executed value, Scheduled date of Work completion and date of Actual work completion etc. The Completion Certificate or equivalent should have been issued by the end-user/owner/authorized consultant.</p> <p>For Running Contract: - Bidder must submit/upload:</p> <p>c) Same documents as mentioned above at point a.</p> <p>d) Copy of Execution Certificate or equivalent against Order/LOA/Contract for the running contract as mentioned at point "a" above must be submitted / uploaded clearly mentioning the executed VALUE till one day prior to unpriced bid opening, which must be equal to or more than the minimum prescribed value mentioned in BEC clause A-I. The execution certificate or equivalent must contain the detailed information like Order/LOA/Contract/Agreement No. with date, Brief Scope of work / Name of work, Order value, Total executed value, etc. The Execution Certificate or equivalent should have been issued by the end user/owner/authorized consultant.</p>

		<p>For Jobs executed for Subsidiary / Fellow subsidiary/ Holding company: -</p> <p>Bidder must submit/upload:</p> <p>Tax paid invoice(s) duly certified by statutory auditor of the bidder towards payments of statutory tax in support of the job executed for Subsidiary / Fellow Subsidiary /Holding Company.</p>
Financial BEC		
B.1	Annual Turnover	<p>Bidder must submit: Audited Financial statements including Balance sheet and Profit & Loss Account etc. for three preceding financial years i.e., FY 2018-19, FY 2019-20 &FY 2020-21</p> <p style="text-align: center;">AND</p> <p>Certificate from Chartered Accountant for details of financial capability (F-16).</p>
B.2	Net Worth	<p>Bidder must submit: Audited Financial statements including Balance sheet and Profit & Loss Account etc. for immediate preceding financial year i.e. in FY 2020-21</p> <p style="text-align: center;">AND</p> <p>Certificate from Chartered Accountant for details of financial capability (F-16)</p>
B.3	Working Capital	<p>Bidder must submit: Audited Financial statements including Balance sheet and Profit & Loss Account etc. for immediate preceding year i.e. in FY 2020-21.</p> <p>In case of inadequate or negative working capital, Letter from the bidder's Bank (as per format in tender document), having net worth not less than Rs. 100 Crores, confirming the availability of the line of credit for at least working capital requirement as stated in BEC.</p> <p style="text-align: center;">AND</p> <p>Certificate from Chartered Accountant for details of financial capability (F-16).</p>

D) Authentication of document submitted in support of Bid Evaluation Criteria (BEC):

- 1) Technical Criteria of BEC: - All work orders/contract agreements and corresponding work completion/execution certificates in support of Technical Criteria of Bid Evaluation Criteria (BEC) to be furnished by the bidders shall necessarily be duly certified / attested by Chartered Engineer and Notary public with legible stamp.
- 2) Financial Criteria of BEC: - Copies of audited annual financial statements submitted in bid in support of Financial Criteria of BEC shall be duly certified / attested by Chartered Accountant and Notary public with legible stamp.

Also, Certificate from Chartered Accountant for details of financial capability of bidder (form F-16) shall be duly signed and stamped by a Chartered Accountant in original

B] AWARD METHODOLOGY

Subject to "ITB: CLAUSES", GNGPL will award the Contract to the successful Bidder whose Bid has been determined to be substantially responsive and has been determined as the lowest provided that bidder, is determined to be qualified to satisfactorily perform the Contract.

Evaluation and order placement shall be done **on overall lowest offer basis**. Bidders are required to quote for full quantity against item(s). In case, bidder quotes for PART QUANTITY OR DOESN'T QUOTE FOR ANY ITEM OF SOR, such bids shall be liable for rejection.

In case it is observed that any bidder has not quoted for any item in the Schedule of Rates (such unquoted item not being in large numbers), the quoted price for the purpose of evaluation shall be considered as the maximum rate quoted by the remaining bidder for such items.

If after evaluation, such bidder is found to be the lowest evaluated bidder, the rates for the missing item shall be considered as included in quoted bid price.

If the estimated price impact of the unquoted items is more than 10% of the bidder's quoted price, the above provision shall not be applicable and such bid shall be rejected.

In case more than one bidder emerges as lowest (L-1) subject to terms and conditions of tender, contract shall be awarded to the bidder who is having higher financial turnover **of last audited financial results**/statements or relevant documents. In such cases, GNGPL may ask for the other financial documents to bidder, if required and bidder shall submit it within prescribed time schedule failing which bid shall be rejected.

Considering the nature of job, splitting of quantities for SOR will not be possible in this tender. **This tender is not split-able or non-dividable**. The bid evaluation shall be done as per the quoted rates in SOR. L1 Contractor shall be arrived after evaluation of the bids on the basis of overall quoted value/price.

In case, there is discrepancies observed in unit rate and total amount for any item in SOR, the unit rate shall be considered for evaluation and price bid analysis.

In case after price bid opening the lowest evaluated bidder (L-1) is not awarded the job/contract for any mistake committed by him in bidding or withdrawal of bid or varying any term in regard thereof, Goa Natural Gas Pvt Ltd. Shall forfeit earnest money (IF APPLICABLE) paid by the bidder and such bidders shall be debarred from participation in tendering for the period of 6 months.

It is proposed to hire 1 nos. of contractor under this tender.

Contractors shall have to quote for all the SOR items for entire quantity of the AMC. If the awarded Contractors could not perform the jobs as per the scope, the same shall be executed by any of the agency at the risk & cost of the non performing contractor and the expenses towards these shall be recovered

Government of India, vide Gazette of India No. 503 dated 26.03.2012 has proclaimed the Public Procurement Policy on procurement of goods and services (not applicable for Works Contracts) from Micro and Small Enterprises (MSEs) by all Central Ministries/ Departments/ PSUs for promotion and development of Micro and Small Enterprises

Accordingly, following provisions shall be applicable for tenders:

- i) Issue of Tender Documents to MSEs free of cost.
- ii) Exemption to MSEs from payment of EMD/Bid Security.
- iii) In Tender, participating Micro and Small Enterprises quoting price within price band of L1+15% shall also be allowed to supply a portion of requirement by bringing down their prices to L1 price in a situation where L1 price is from someone other than a micro and small enterprises and such micro and small enterprises shall be allowed to supply up to 20% of the total tendered value. In case of more than one such Micro and Small Enterprises, the supply shall be shared proportionately (to tendered quantity). Further, out of above 20%, 4% (20% of 20%) shall be from MSEs owned by SC/ST entrepreneurs. This quota is to be transferred to other MSEs in case of non-availability of MSEs owned by SC/ST entrepreneurs.

In case tendered item is non-split able or non-dividable, MSE quoting price within price band L1 (other than MSE) +15%, may be awarded for full / complete value of supplies / contract subject to matching of L1 price. In case two or more MSE bidder(s) comes within the price band of L1+15%, the preference to match the L1 rate shall be given in sequence of their inter-se position (L2, L3...and so on).

The MSEs owned by SC/ST entrepreneurs shall mean:

- a) In case of Proprietary MSE, Proprietor(s) shall be SC/ST
- b) In case of Partnership MSE, the SC/ST partners shall be holding at least 51% share in the unit.
- c) In case of Private Limited Companies, at least 51% share is held by SC/ST. If the MSE is owned by SC/ST Entrepreneurs, the bidder shall furnish appropriate documentary evidence in this regard.

The quoted prices against various items shall remain valid in case of splitting of quantities of the items as above.

As per communication of MSME vide its letter no. F. No. 21(12)2016-MA dated 15.06.2018, Provision of Public Procurement Policy for MSEs-2012 and its benefits will be applicable for procurement of Goods and Services only and not for Procurement of Works.

As per communication of MSME vide its letter No. 21 (12) / 2016-MA dated 23.08.2018, Tender Fee and EMD exemption are to be given to the participating MSE bidders in tender for procurement of Works.

Accordingly, necessary provision may please be kept in the tender for procurement of WORKS clearly stipulating that MSE bidders are exempted from submission/ payment of EMD / BID security. But such participating MSE bidders are not entitled for purchase preference in tenders for procurement of WORKS.

The Public Procurement Policy for MSEs is meant for procurement of only goods produced & Services rendered by MSEs. The benefit of policy is not extended to the traders/dealers/ Distributors/Stockiest/Wholesalers.

CLAUSE REGARDING PROVISION FOR PROCUREMENT FROM A BIDDER WHICH SHARES A LAND BORDER WITH INDIA - NOT APPLICABLE

PROVISIONS FOR STARTUPS (AS DEFINED IN GAZETTE NOTIFICATION NO. D.L-33004/99 DATED 18.02.2016 AND 23.05.2017 OF MINISTRY OF COMMERCE AND INDUSTRY AND AS AMENDED FROM TIME TO TIME) - NOT APPLICABLE

POLICY TO PROVIDE PURCHASE PREFERENCE (LINKED WITH LOCAL CONTENT) (PP-LC) - NOT APPLICABLE

SECTION-II **PART-2: OTHER INSTRUCTIONS TO BIDDERS**

INDEX

[A] GENERAL:

1. SCOPE OF BID
2. ELIGIBLE BIDDERS
3. BIDS FROM CONSORTIUM / JOINT VENTURE
4. ONE BID PER BIDDER
5. COST OF BIDDING & TENDER FEE
6. SITE-VISIT

[B] BIDDING DOCUMENTS:

7. CONTENTS OF BIDDING DOCUMENTS
8. CLARIFICATION OF BIDDING DOCUMENTS
9. AMENDMENT OF BIDDING DOCUMENTS

[C] PREPARATION OF BIDS:

10. LANGUAGE OF BID
11. DOCUMENTS COMPRISING THE BID
12. SCHEDULE OF RATES / BID PRICES
13. GST
14. BID CURRENCIES
15. BID VALIDITY
16. EARNEST MONEY / BID SECURITY
17. PRE-BID MEETING
18. FORMAT AND SIGNING OF BID
19. ZERO DEVIATION & REJECTION CRITERIA
20. E-PAYMENT

[D] SUBMISSION OF BIDS:

21. SUBMISSION, SEALING AND MARKING OF BIDS
22. DEADLINE FOR SUBMISSION OF BIDS
23. LATE BIDS
24. MODIFICATION AND WITHDRAWAL OF BIDS

[E] BID OPENING AND EVALUATION:

25. EMPLOYER'S RIGHT TO ACCEPT ANY BID AND TO REJECT ANY OR ALL BIDS
26. BID OPENING
27. CONFIDENTIALITY
28. CONTACTING THE EMPLOYER
29. EXAMINATION OF BIDS AND DETERMINATION OF RESPONSIVENESS
30. CORRECTION OF ERRORS
31. CONVERSION TO SINGLE CURRENCY FOR COMPARISON OF BIDS
32. EVALUATION AND COMPARISON OF BIDS
33. COMPENSATION FOR EXTENDED STAY
34. PURCHASE PREFERENCE

[F] AWARD OF CONTRACT:

35. AWARD
36. NOTIFICATION OF AWARD / FAX OF ACCEPTANCE [FOA]
37. SIGNING OF AGREEMENT
38. CONTRACT PERFORMANCE SECURITY / SECURITY DEPOSIT
39. AHR ITEMS
40. PUBLIC PROCUREMENT POLICY FOR MICRO AND SMALL ENTERPRISE
41. VENDOR EVALUATION PROCEDURE
42. INCOME TAX & CORPORATE TAX
43. SETTLEMENT OF DISPUTES BETWEEN GOVERNMENT DEPARTMENT AND ANOTHER AND ONE GOVERNMENT DEPARTMENT AND PUBLIC ENTERPRISE AND ONE PUBLIC ENTERPRISE AND ANOTHER

[A] – GENERAL

1 SCOPE OF BID

- 1.1 The Employer/ Owner/ GNGPL as defined in the "General Conditions of Contract [GCC]", wishes to receive Bids as described in the Bidding Document/Tender document issued by Employer/Owner/GNGPL.
- 1.2 SCOPE OF BID: The scope of work/ Services shall be as defined in the Bidding documents.
- 1.3 The successful bidder will be expected to complete the scope of Bid within the period stated in Special Conditions of Contract.
- 1.4 Throughout the Bidding Documents, the terms 'Bid', 'Tender' & 'Offer' and their derivatives [Bidder/Tenderer, Bid/Tender/Offer etc.] are synonymous. Further, 'Day' means 'Calendar Day' and 'Singular' also means 'Plural'.

2 ELIGIBLE BIDDERS

- 2.1 The Bidder shall not be under a declaration of ineligibility by Employer for Corrupt/ Fraudulent/ Collusive/ Coercive practices, as defined in "Instructions to Bidders [ITB], Clause No. 39" (Action in case Corrupt/ Fraudulent/ Collusive/ Coercive Practices).
- 2.2 The Bidder is not put on 'Holiday' by GNGPL or Public Sector Project Management Consultant (like EIL, Mecon only due to "poor performance" or "corrupt and fraudulent practices") or banned/blacklisted by Government department/ Public Sector on due date of submission of bid. If the bidding documents were issued inadvertently/ downloaded from website, offers submitted by such bidders shall not be considered for opening/ evaluation/Award and will be returned immediately to such bidders.

In case there is any change in status of the declaration prior to award of contract, the same has to be promptly informed to GNGPL by the bidder.

It shall be the sole responsibility of the bidder to inform GNGPL in case the bidder is put on 'Holiday' by GNGPL or Public Sector Project Management Consultant (like EIL, Mecon. only due to "poor performance" or "corrupt and fraudulent practices") or banned/blacklisted by Government department/ Public Sector on due date of submission of bid and during the course of finalization of the tender. Concealment of the facts shall tantamount to misrepresentation of facts and shall lead to action against such Bidders as per clause 39 of ITB.

- 2.3 The Bidder should not be under any liquidation court receivership or similar proceedings on due date of submission of bid.
In case there is any change in status of the declaration prior to award of contract, the same has to be promptly informed to GNGPL by the bidder.
It shall be the sole responsibility of the bidder to inform GNGPL in case the bidder is under any liquidation court receivership or similar proceedings on due date of submission of bid and during the course of finalization of the tender. Concealment of the facts shall tantamount to misrepresentation of facts and shall lead to action against such Bidders as per clause no.39 of ITB.

- 2.4 Bidder shall not be affiliated with a firm or entity:
- (i) that has provided consulting services related to the work to the Employer during the preparatory stages of the work or of the project of which the works/services form a part of or
 - (ii) that has been hired (proposed to be hired) by the Employer as an Engineer/ Consultant for the contract.
- 2.5 Neither the firm/entity appointed as the Project Management Consultant (PMC) for a contract nor its affiliates/ JV'S/ Subsidiaries shall be allowed to participate in the tendering process unless it is the sole Licensor/Licensor nominated agent/ vendor.
- 2.6 Pursuant to qualification criteria set forth in the bidding document, the Bidder shall furnish all necessary supporting documentary evidence to establish Bidder's claim of meeting qualification criteria.

4 ONE BID PER BIDDER

- 4.1 A Firm/Bidder shall submit only 'one [01] Bid' in the same Bidding Process. A Bidder who submits or participates in more than 'one [01] Bid' will cause all the proposals in which the Bidder has participated to be disqualified.
- 4.2 Alternative Bids shall not be considered.

5 COST OF BIDDING & TENDER FEE

5.1 COST OF BIDDING

The Bidder shall bear all costs associated with the preparation and submission of the Bid including but not limited to Bank charges all courier charges including taxes & duties etc. incurred thereof. Further, GNGPL will in no case, be responsible or liable for these costs, regardless of the outcome of the bidding process.

6 SITE VISIT

- 6.1 The Bidder is advised to visit and examine the site of works and its surroundings and obtain for itself on its own responsibility all information that may be necessary for preparing the Bid and entering into a Contract for the required job. The costs of visiting the site shall be borne by the Bidder.
- 6.2 The Bidder or any of its personnel or agents shall be granted permission by the Employer to enter upon its premises and land for the purpose of such visits, but only upon the express conditions that the Bidder, its personnel and agents will release and indemnify the Employer and its personnel, agents from and against all liabilities in respect thereof, and will be responsible for death or injury, loss or damage to property, and any other loss, damage, costs, and expenses incurred as a result of inspection.
- 6.3 The Bidder shall not be entitled to hold any claim against GNGPL for non-compliance due to lack of any kind of pre-requisite information as it is the sole responsibility of the Bidder to obtain all the necessary information with regard to site, surrounding, working conditions, weather etc. on its own before submission of the bid.

[B] – BIDDING DOCUMENTS

7 CONTENTS OF BIDDING DOCUMENTS

7.1 The contents of Bidding Documents / Tender Documents are those stated below, and should be read in conjunction with any 'Addendum / Corrigendum' issued in accordance with "ITB: Clause-9":

- Section – I: Invitation for Bids (IFB)
- Section – II Instructions to Bidders (ITB)
- Section – III Special Conditions of Contracts (SCC)
- Section – IV General Conditions of Contracts (GCC)
- Section – V Forms and Formats
- Section – VI Schedule of Rates (SOR)

*Request for Quotation', wherever applicable, shall also form part of the Bidding Document.

7.2 The Bidder is expected to examine all instructions, forms, terms & conditions in the Bidding Documents. The ITB, SCC, GCC & Invitation for Bid (IFB) together with all its attachments thereto, shall be considered to be read, understood and accepted by the Bidders. Failure to furnish all information required by the Bidding Documents or submission of a Bid not substantially responsive to the Bidding Documents in every respect will be at Bidder's risk and may result in the rejection of his Bid.

8 CLARIFICATION OF BIDDING DOCUMENTS

8.1 A prospective Bidder requiring any clarification(s) of the Bidding Documents may notify GNGPL in writing or by fax or email at GNGPL's mailing address indicated in the BDS no later than **02 (two)** days prior to pre-bid meeting (in cases where pre-bid meeting is scheduled) or **05 (five) days** prior to the bid closing date in cases where pre-bid meeting is not held. GNGPL reserves the right to ignore the bidders request for clarification if received after the aforesaid period. GNGPL may respond in writing to the request for clarification. Communicated to prospective bidders by e-mail/ fax.

8.2 Any clarification or information required by the Bidder but same not received by the Employer at clause 8.1 (refer IFB for address) above is liable to be considered as "no clarification / information required".

9 AMENDMENT OF BIDDING DOCUMENTS

9.1 At any time prior to the 'Bid Due Date', Owner may, for any reason, whether at its own initiative or in response to a clarification requested by a prospective Bidder, modify the Bidding Documents by addenda/ corrigendum.

9.2 Any addendum/ corrigendum thus issued shall be part of the Bidding Documents and may be communicated to prospective bidders by hosting in the websites only. Bidders have to take into account all such addendum/ corrigendum before submitting their bid.

9.3 The Employer, if consider necessary, may extend the date of submissions of Bid in order to allow the Bidders a reasonable time to furnish their most competitive bid taking into account the amendment issued thereof.

[C] – PREPARATION OF BIDS

10 LANGUAGE OF BID:

The bid prepared by the bidder and all correspondence/drawings and documents relating to the bid exchanged by bidder and GNGPL shall be written in English language alone. Any printed literature furnished by the bidder may be written in another language as long as accompanied by an ENGLISH translation duly authenticated by the chamber of commerce of bidder's country, in which case, for the purpose of interpretation of the bid, the ENGLISH translation shall govern.

In the event of submission of any document/certificate by the Bidder in a language other than English, the English translation of the same duly authenticated by Chamber of Commerce of Bidder's country shall be submitted by the Bidder.

11. DOCUMENTS COMPRISING THE BID

11.1 In case the Bids are invited under the **MANUAL TWO BID SYSTEM**.

The Bid prepared by the Bidder shall comprise the following components sealed in **2 DIFFERENT ENVELOPES**:

11.1.1 ENVELOPE-I:

"TECHNO-COMMERCIAL / UN-PRICED BID" shall contain the following:

- i. As a confirmation that the prices are quoted in requisite format complying with the requirements of **Schedule of Rate (SOR)** with prices blanked out mentioning quoted / not quoted (as applicable) written against each item. This is to be submitted on blank SOR copy.
- ii. Duly attested documents in accordance with the "BID EVALUATION CRITERIA [BEC]" establishing the qualification.
- iii. Power of Attorney for **authorized signatory** on non-judicial stamp paper OR on letterhead/copy of Board Resolution, the authorized signatory shall be signing the bid and any consequence resulting due to such signing shall be binding on the bidder.
- iv. EMD/Bid Security in original as per Clause 16 of ITB
- v. All applicable forms/Formats/Annexures duly filled, signed and stamped.
APPLICABILITY OF FORMS/FORMATS/ANNEXURES FOR THIS TENDER IS MENTIONED IN SECTION V AND VI OF TENDER.
- vi. Tender Document duly signed/ digitally signed and stamped all pages by the Authorized Signatory.
- vii. Additional document specified/mentioned elsewhere in Tender.

Note: All the pages of the Bid must be signed by the "Authorized Signatory" of the Bidder.

11.1.2 ENVELOPE-II: PRICE BID

ONLY SCHEDULE OF RATE WITH QUOTED PRICES DULY SIGNED AND STAMPED BY AUTHORIZED PERSON SHALL BE SUBMITTED IN ENVELOPE-II.

NOTES:

- (i) The Prices are to be submitted strictly as per the Schedule of Rate of the bidding documents. GNGPL shall not be responsible for any failure on the part of the bidder to follow the instructions.
- (ii) Bidders are advised NOT to mention Rebate/Discount separately, either in the SOR format or anywhere else in the offer. In case Bidder(s) intend to offer any Rebate/Discount, they should include the same in the item rate(s) itself under the "Schedule of Rates (SOR)" and indicate the discounted unit rate(s) only.
- (iii) If any unconditional rebate has been offered in the quoted rate the same shall be considered in arriving at evaluated price. However, no cognizance shall be taken for any conditional discount for the purpose of evaluation of the bids.
- (iv) In case, it is observed that any of the bidder(s) has/have offered Suo-moto Discount/Rebate after opening of unpriced bid but before opening of price bids such discount /rebate(s) shall not be considered for evaluation. However, in the event of the bidder emerging as the lowest evaluated bidder without considering the discount/rebate(s), then such discount/rebate(s) offered by the bidder shall be considered for Award of Work and the same will be conclusive and binding on the bidder.
- (v) In the event as a result of techno-commercial discussions or pursuant to seeking clarifications / confirmations from bidders, while evaluating the un-priced part of the bid, any of the bidders submits a sealed envelope stating that it contains revised prices; such bidder(s) will be requested to withdraw the revised prices failing which the bid will not be considered for further evaluation.
- (vi) In case it is observed that any bidder has not quoted for any item in the Schedule of Rates (such unquoted item not being in large numbers), the quoted price for the purpose of evaluation shall be considered as the maximum rate quoted by the remaining bidder for such items.
- (vi) If after evaluation, such bidder is found to be the lowest evaluated bidder, the rates for the missing item shall be considered as included in quoted bid price. If the estimated price impact of the unquoted items is more than 10% of the bidder's quoted price, the above provision shall not be applicable and such bid shall be rejected.

Note: The above provision should invariably be made a part of tender document. "Rates should be quoted both in figures as well as in words by the bidders".

12 SCHEDULE OF RATES / BID PRICES

- 12.1 Unless stated otherwise in the Bidding Documents, the Contract shall be for the whole works as described in Bidding Documents, based on the rates and prices submitted by the Bidder and accepted by the Employer. The prices quoted by the Bidders will be inclusive of all taxes except GST.
- 12.2 Prices must be filled in format for "Schedule of Rates [SOR]" enclosed as part of Tender document. If quoted in separate typed sheets and any variation in item description, unit or quantity is noticed; the Bid is liable to be rejected.
- 12.3 Bidder shall quote for all the items of "SOR" after careful analysis of cost involved for the performance of the completed item considering all parts of the Bidding Document. In case any activity though specifically not covered in description of item under "SOR" but is required to complete the works as per Specifications, Scope of Work / Service, Standards, "GCC", "SCC" or any other part of Bidding Document, the prices quoted shall deemed to be inclusive of cost incurred for such activity.
- 12.4 All duties, taxes [except GST and Cess thereon] and other levies [if any] payable by the Contractor under the Contract, or for any other cause, shall be included in the rates / prices and the total bid-price submitted by the Bidder. Applicable rate of GST shall be indicated in Agreed Terms & Conditions (Format-F10).
- 12.5 Prices quoted by the Bidder, shall remain firm and fixed and valid until completion of the Contract and will not be subject to variation on any account. Any new taxes & Duties, if imposed by the State/ Govt. of India after the last date of bid submission but before the Contractual Delivery Date, shall be reimbursed to the contractor on submission of documentary evidence for proof of payment to State/ Govt. Authorities and after ascertaining its applicability with respect to the contract.
- 12.6 The Bidder shall quote the prices in 'figures' & words. There should not be any discrepancy between the prices indicated in figures and the price indicated in words. In case of any discrepancy, the same shall be dealt as per clause no. 30 of ITB.

13 TAXES & DUTIES

- 13.1 Within the contractual delivery period, the statutory variation in applicable GST (CGST & SGST/UTGST or IGST) on supply and on incidental services shall be to GNGPL's account. Beyond the contractual delivery period, any increase in the rate of GST (CGST & SGST/UTGST or IGST) shall be to Supplier's account, whereas any decrease in the rate GST (CGST & SGST/UTGST or IGST) shall be passed on to the Purchaser.

The base date for the purpose of applying statutory variation shall be the Bid Due Date.

- 13.2 In case of statutory variation(s) in the taxes & duties mentioned above, the Supplier shall submit a copy of the 'Government Notification' to evidence the rate as applicable on the Bid Due Date and on the date of revision. Claim for payment of statutory variation should be raised preferably along with the Invoice. Any claim for arrears on account of statutory variation shall be submitted to Purchaser within two [02] months from the date of issue of such 'Government Notification', otherwise such claim may not be entertained.

- 13.3 For Indian Bidder only: With respect to clause no. 11.1.1 D) and 11.1.2, the statutory variation in Import Duty on CIF value indicated, within contractual delivery period shall be to Purchaser's account against submission of the documentary evidence. However, any increase in the rate of Import Duty beyond the contractual delivery / completion period shall be to Bidder's account. In case of wrong classification, no variation including statutory variation of Import Duty will be payable to Supplier and any penalty due to the same shall be to Supplier's account. Any decrease in the rate of Import Duty shall be passed on to the Purchaser.
- 13.4 New Taxes & duties: Any new taxes & duties, if imposed by the State/ Central Govt. of India on the finished goods after the due date of bid submission but before the Contractual Delivery/Completion Date, shall be reimbursed to the Supplier on submission of copy of notification(s) issued from State/ Central Govt. Authorities along with documentary evidence for proof of payment of such taxes & duties, but only after ascertaining its applicability with respect to the Contract.
- 13.5 Deemed Export benefits are not applicable and Bidder should furnish prices without considering the same.
- 13.6 Supplier shall ensure timely submission of correct invoice(s), as per GST rules/ regulation, with all required supporting document(s) within a period specified in Contract to enable GNGPL to avail input credit of GST (CGST & SGST/UTGST or IGST). Further, returns and details required to be filled under GST laws & rules should be timely filed by Supplier of Goods / Services with requisite details.
- 13.7 The supplier shall mention the particulars of Goa Natural Gas Private Limited, on the Invoice. Besides, if any other particulars of GNGPL are required to be mentioned, under GST rules/regulations on the date of dispatch, the same shall also be mentioned on the Invoice.
- 13.8 In case CBEC (Central Board of Excise and Customs)/ any equivalent government agency brings to the notice of GNGPL that the Supplier has not remitted the amount towards GST (CGST&SGST/UTGST or IGST) collected from GNGPL to the government exchequer, then, that Supplier shall be put under Holiday list of GNGPL for period of six months as mentioned in Procedure for Evaluation of Performance of Vendors/ Suppliers/Contractors/ Consultants.
- 13.9 GNGPL will prefer to deal with registered supplier of goods/ services under GST. Therefore, bidders are requested to get themselves registered under GST, if not registered yet. However, in case any unregistered bidder/ Indian associate (in case of foreign bidder, if applicable), prices will be loaded with applicable GST (CGST&SGST/UTGST or IGST) during evaluation of bid.
- 13.10 In case the GST rating of vendor on the GST portal / Govt. official website is negative / black listed, then the bids may be rejected by GNGPL. Further, in case rating of bidder is negative / black listed after award of work for supply of goods / services, then GNGPL shall not be obligated or liable to pay or reimburse GST (CGST&SGST/UTGST or IGST) to such vendor and shall also be entitled to deduct / recover such GST (CGST&SGST/UTGST or IGST) along with all penalties / interest, if any, incurred by GNGPL.

- 13.11 Anti-profiteering clause as per Clause 171 of GST Act, it is mandatory to pass on the benefit due to reduction in rate of tax or from input tax credit to the consumer by way of commensurate reduction in prices. The Supplier/ Service Provider may note the above and quote their prices accordingly. (A confirmation to above will be submitted on letterhead of the bidder).
- 13.12 The bidder while quoting the price may consider the rate of custom duty as per merit.
- 13.13 Where GNGPL has the obligation to discharge GST (CGST & SGST/UTGST or IGST) liability under reverse charge mechanism and GNGPL has paid or is /liable to pay GST (CGST & SGST/UTGST or IGST) to the Government on which interest or penalties becomes payable as per GST laws for any reason which is not attributable to GNGPL or ITC with respect to such payments is not available to GNGPL for any reason which is not attributable to GNGPL, then GNGPL shall be entitled to deduct/ setoff / recover such amounts against any amounts paid or payable by GNGPL to Contractor / Supplier.
- 13.14 If the input tax credit is not available to GNGPL for any reason not attributable to GNGPL, then GNGPL shall not be obligated or liable to pay or reimburse GST (CGST & SGST/UTGST or IGST) claimed in the invoice(s) and shall be entitled to deduct /setoff / recover such GST amount (CGST & SGST/UTGST or IGST) or Input Tax Credit amount together with penalties and interest, if any, against any amounts paid or becomes payable by GNGPL in future to the Supplier/Contractor under this contract or under any other contract.

14 BID CURRENCIES:

Bidders must submit bid in Indian Rupees only.

15 BID VALIDITY

- 15.1 Bids shall be kept valid for '**THREE [03] MONTHS**' from the final 'Bid Due Date'. A Bid valid for a shorter period may be rejected by GNGPL as 'non-responsive'.
- 15.2 In exceptional circumstances, prior to expiry of the original 'Bid Validity Period', the Employer may request the Bidders to extend the 'Period of Bid Validity' for a specified additional period. The request and the responses thereto shall be made in writing or by fax/email. A Bidder may refuse the request without forfeiture of his 'Bid Security'. A Bidder agreeing to the request will not be required or permitted to modify his Bid, but will be required to extend the validity of its 'Bid Security' for the period of the extension and in accordance with "ITB: Clause-16" in all respects.

16 EARNEST MONEY/BID SECURITY

- 16.1 Bids must be accompanied with 'Earnest Money / Bid Security' in the form of 'Demand Draft' [in favor of Goa Natural Gas Pvt. Ltd., payable at North Goa] or 'Banker's Cheque' or 'Bank Guarantee' or online or 'Letter of Credit' as per the format given in Form -4/4A of the bidding documents. Bidders shall ensure that 'Bid Security', having a validity of at least 'two [02] months' beyond the validity of the bid, must accompany the Bid in the format(s) made available in the Bidding Document. Bid not accompanied with 'Bid Security', or 'Bid Security' not in requisite form shall be liable for rejection. The Bid Security shall be submitted in Indian Rupees only. The details of the GNGPL A/C for online payment is as mentioned below.

Account Title: GOA NATURAL GAS PRIVATE LIMITED.
Account no: 201001033459 ; RTGS code: INDB0000088.
RTGS IFSC and NEFT IFSC: INDB0000088. 9 Digit MICR code 403234002.

OR

Bank Name: SBI, Panaji
Account Title: GOA NATURAL GAS PRIVATE LIMITED.
Account no: 37639813076
IFSC Code: SBIN0004212

- 16.2 The 'Bid Security' is required to protect GNGPL against the risk of Bidder's conduct, which would warrant the 'Bid Security's' forfeiture, pursuant to "ITB: Clause-16.7".
- 16.3 GNGPL shall not be liable to pay any Bank charges, commission or interest etc. on the amount of 'Bid Security'. In case 'Bid Security' is in the form of a 'Bank Guarantee', the same shall be from any Indian scheduled Bank or a branch of an International Bank situated in India and registered with 'Reserve Bank of India' as Scheduled Foreign Bank. However, in case of 'Bank Guarantee' from Banks other than the Nationalized Indian Banks, the Bank must be commercial Bank having net worth in excess of Rs. 100 Crores [Rupees One Hundred Crores] and a declaration to this effect should be made by such commercial Bank either in the 'Bank Guarantee' itself or separately on its letterhead. 'Earnest Money / Bid Security' shall be valid for 'two [02] months' beyond the 'Bid Validity Period'
- 16.4 Any Bid not secured in accordance with "ITB: Clause-16.1 & Clause-16.3" may be rejected by GNGPL as non-responsive.
- 16.5 Unsuccessful Bidder's 'Earnest Money / Bid Security' will be discharged/ returned as promptly as possible, but not later than 'thirty [30] days' after finalization of tender .
- 16.6 The successful Bidder's 'Bid Security' will be discharged upon the Bidder's acknowledging the 'Award' and signing the 'Agreement' and furnishing the 'Contract Performance Security / Security Deposit' pursuant to clause 37 & 38 of ITB.
- 16.7 Notwithstanding anything contained herein, the 'Bid Security' may also be forfeited in any of the following cases:
- (a) If a Bidder withdraws his Bid during the 'Period of Bid Validity'
 - (b) If a Bidder has indulged in corrupt/fraudulent /collusive/coercive practice
 - (c) If the Bidder modifies bids during the period of bid validity (after submission date).
 - (d) Violates any other condition, mentioned elsewhere in the tender document, which may lead to forfeiture of EMD.
 - (e) In the case of a successful Bidder, if the Bidder fails to:
 - (i) to acknowledge receipt the "Notification of Award" / "Fax of Intent [FOI]/ Fax of Acceptance[FOA]",
 - (ii) to furnish "Contract Performance Security / Security Deposit", in accordance with "ITB: Clause-38"
 - (iii) to accept 'arithmetical corrections' as per provision of the clause 30 of ITB.
- 16.8 Bid Security should be in favor of GNGPL and addressed to GNGPL. In case Bid Security is in the form of 'Bank Guarantee' or 'Letter of Credit', the same must indicate the Bid Document No. and the Work for which the Bidder is quoting. This is essential to

have proper correlation at a later date. The 'Bid Security' should be in the form provided at 'Form F-4'/'Form F-4A'.

- 16.9 Wherever applicable, MSEs (Micro & Small Enterprises) are exempted from submission of EMD/Bid Security in accordance with the provisions of PPP-2012 and Clause 40 of ITB. The Government Departments/PSUs are also exempted from the payment of Bid Security.

17 PRE-BID MEETING

- 17.1 The Bidder(s) or his designated representative are invited to attend a "Pre-Bid Meeting" which will be held at address specified in IFB. It is expected that a bidder shall not depute more than 02 representatives for the meeting.

In case of pre-bid meeting through video conferencing, all bidders intending to attend pre-bid meeting must send their interest through email prior to 02 days before pre bid meeting date as specified in IFB

- 17.2 Purpose of the meeting will be to clarify issues and to answer questions on any matter that may be raised at that stage and give hands-on e-tendering, if applicable.
- 17.3 Text of the questions raised and the responses given, together with any responses prepared after the meeting, will be uploaded on GNGPL website against the Tender. Any modification of the Contents of Bidding Documents listed in "ITB: Clause-7.1", that may become necessary as a result of the Pre-Bid Meeting shall be made by the Employer exclusively through the issue of an Addendum / Corrigendum pursuant to "ITB: Clause-9", and not through the minutes of the Pre-Bid Meeting.
- 17.4 Non-attendance of the Pre-Bid Meeting will not be a cause for disqualification of Bidder.

18 FORMAT AND SIGNING OF BID

- 18.1 The original and all copies of the Bid shall be typed or written in indelible ink [in the case of copies, photocopies are also acceptable] and shall be signed by a person or persons duly authorized to sign on behalf of the Bidder (as per POA). The name and position held by each person signing, must be typed or printed below the signature. All pages of the Bid except for unamended printed literature where entry(s) or amendment(s) have been made shall be initiated by the person or persons signing the Bid.
- 18.2 The Bid shall contain no alterations, omissions, or additions, unless such corrections are initiated by the person or persons signing the Bid.
- 18.3 In case of e-tendering - NOT-APPLICABLE

19 ZERO DEVIATION AND REJECTION CRITERIA

- 19.1 ZERO DEVIATION: Deviation to terms and conditions of "Bidding Documents" may lead to rejection of bid. GNGPL will accept bids based on terms & conditions of "Bidding Documents" only. Bidder may note GNGPL will determine the substantial responsiveness of each bid to the Bidding Documents pursuant to provision contained in clause 29 of ITB. For purpose of this, a substantially responsive bid is one which conforms to all terms and conditions of the Bidding Documents without deviations or reservations. GNGPL's determination of a bid's responsiveness is based on the content

of the bid itself without recourse to extrinsic evidence. GNGPL reserves the right to raise technical and/or commercial query(s), if required, may be raised on the bidder(s). The response(s) to the same shall be in writing, and no change in the price(s) or substance of the bids shall be sought, offered or permitted. The substance of the bid includes but not limited to prices, completion, scope, technical specifications, etc. Bidders are requested to not to take any deviation/exception to the terms and conditions laid down in this "Tender Documents", and submit all requisite documents as mentioned in this "Tender Documents", failing which their offer will be liable for rejection. If a bidder does not reply to the queries in the permitted time frame, then its bid shall be evaluated based on the documents available in the bid.

19.2 **REJECTION CRITERIA:** Notwithstanding the above, deviation to the following clauses of Tender document shall lead to summarily rejection of Bid:

- (a) Firm Price
- (b) Earnest Money Deposit / Bid Security, if required
- (c) Specifications & Scope of Work
- (d) Schedule of Rates / Price Schedule / Price Basis
- (e) Duration / Period of Contract/ Completion schedule
- (f) Period of Validity of Bid
- (g) Price Reduction Schedule
- (h) Contract Performance Bank Guarantee / Security Deposit, If required
- (i) Guarantee / Defect Liability Period, if required
- (j) Arbitration / Resolution of Dispute/Jurisdiction of Court
- (k) Force Majeure & Applicable Laws
- (l) Integrity Pact, if Applicable
- (m) Any other condition specifically mentioned in the tender document elsewhere that non-compliance of the clause lead to rejection of bid

Note: Further, it is once again reminded not to mention any condition in the Bid which is contradictory to the terms and conditions of Tender document.

20 **E-PAYMENT**

GNGPL has initiated payments to Suppliers and Contractors electronically, and to facilitate the payments electronically through '**e-banking**'. The successful bidder should give the details of his bank account as per the bank mandate form.

[D] – SUBMISSION OF BIDS

21 SUBMISSION, SEALING AND MARKING OF BIDS

- 21.2 In case of manual tendering bid must be submitted in sealed envelope. If the envelope is not sealed & marked as per Clause No. 11 of ITB, the employer will assume no responsibility for misplacement or pre-mature opening of the bid.
- 21.3 All the bids shall be addressed to the owner at address specified in IFB.
- 21.4 Bids submitted under the name of AGENT/ CONSULTANT/ REPRESENTATIVE /RETAINER/ ASSOCIATE etc. on behalf of a bidder/affiliate shall not be accepted.

22 DEADLINE FOR SUBMISSION OF BIDS

- 22.1 In case of manual tendering EMD along with bid must be submitted within the due date & time.
- 22.2 GNGPL may, in exceptional circumstances and at its discretion, extend the deadline for submission of Bids (clause 9 of ITB refers). In which case all rights and obligations of GNGPL and the Bidders, previously subject to the original deadline will thereafter be subject to the deadline as extended. Notice for extension of bid submission date will be uploaded on GNGPL's website/ communicate to the bidders.

23 LATE BIDS

- 23.1 Any bids received after the notified date and time of closing of tenders will be treated as late bids.
- 23.2 In case of e-tendering, e-tendering system of GNGPL shall close immediately after the deadline for submission of bid and no bids can be submitted thereafter.
In case of manual tendering, bids received by GNGPL after the deadline for submission of bids shall not be considered. Such late bids shall be returned to the bidder within "10 days" in 'unopened conditions. The bid bond of such bidders shall be returned along with the un-opened bid. In case of e-tendering, where the bid bond/physical documents have been received but the bid is not submitted by the bidder in the e-tendering portal, such bid bond/ physical documents shall be returned immediately.
- 23.3 Unsolicited Bids or Bids received to address other than one specifically stipulated in the tender document will not be considered for evaluation/opening/award if not received to the specified destination within stipulated date & time.

24 MODIFICATION AND WITHDRAWAL OF BIDS

24.1 IN CASE OF MANUAL BIDDING

The bidder may withdraw or modify its bid after bid submission but before the due date for submission as per tender document provided that the written notice of the modification/ substitution/ withdrawal is received by GNGPL prior to the deadline for submission of bid.

- 24.2 The modification shall also be prepared, sealed, marked and dispatched in accordance with the provision of clause 22 of ITB, with the outer and inner envelopes additionally marked modification or withdrawal as appropriate. A withdrawal notice may also be sent by e-mail or fax but followed by a signed confirmation copy post not later than the deadline for submission of bids. No bid shall be modified/ withdrawn after the deadline for submission of bids.
- 24.3 No bid shall be allowed to be withdrawn/ modified/substituted in the interval between the deadline for submission of bids and the expiration of the period of bid validity specified by the bidder on the Bid Form. Withdrawal/Modification/Substitution of a bid during this interval shall result in the bidder's forfeiture of his bid security pursuant to clause 16 of ITB.
- 24.4 The latest bid hence submitted shall be considered for evaluation and all other bids shall be considered to be unconditionally withdrawn.
- 24.5 In case after price bid opening the lowest evaluated bidder (L1) is not awarded the job for any mistake committed by him in bidding or withdrawal of bid or modification of bid or varying any term in regard thereof leading to re-tendering, GNGPL shall forfeit EMD paid by the bidder and such bidders shall be debarred from participation in re-tendering of the same job(s)/item(s). Further, such bidder will be put on holiday for a period of six months after following the due procedure.

25 EMPLOYER'S RIGHT TO ACCEPT ANY BID AND TO REJECT ANY OR ALL BIDS

GNGPL reserves the right to accept or reject any Bid, and to annul the Bidding process and reject all Bids, at any time prior to award of Contract, without thereby incurring any liability to the affected Bidder or Bidders or any obligations to inform the affected Bidder or Bidders of the ground for GNGPL Gas's action. However, Bidder if so, desire may seek the reason (in writing) for rejection of their Bid to which GNGPL shall respond quickly.

[E] BID OPENING AND EVALUATION

26 BID OPENING

26.1 *TECHNO-COMMERCIAL / UN-PRICED BID OPENING:*

GNGPL will open bids, in the presence of bidders' designated representatives who choose to attend, at date, time and location stipulated in the IFB/tender. The bidders' representatives, who are present shall sign a bid opening register evidencing their attendance.

26.2 *PRICED BID OPENING:*

26.2.1 GNGPL will open the price bids of those bidders who meet the qualification requirement and whose bids is determined to be technically and commercially responsive. Bidders selected for opening of their price bids shall be informed about the date of price bid opening. Bidders may depute their authorized representative to attend the bid opening. The bidders' representatives, who are present shall sign a register evidencing their attendance and may be required to be present on a short notice.

26.2.2 The price bids of those bidders who were not found to be techno-commercially responsive shall be unopened and returned unopened after opening of the price bids of techno-commercially responsive bidders.

26.3 In case of bids invited under the single bid system, bid shall be opened on the specified due date & time.

27 CONFIDENTIALITY

Information relating to the examination, clarification, evaluation, and comparison of Bids, and recommendations for the award of a Contract, shall not be disclosed to Bidders or any other persons not officially concerned with such process. Any effort by a Bidder to influence the Employer's processing of Bids or award decisions may result in the rejection of the Bidder's Bid.

28 CONTACTING THE EMPLOYER

28.1 From the time of Bid opening to the time of award of Contract, if any Bidder wishes to contact the Employer on any matter related to the Bid, it should do so in writing. Information relating to the examination, clarification, evaluation & recommendation for award shall not be disclosed.

28.2 Any effort by the Bidder to influence the Employer in the Employer's 'Bid Evaluation', 'Bid Comparison', or 'Contract Award' decisions may result in the rejection of the Bidder's Bid.

29 EXAMINATION OF BIDS AND DETERMINATION OF RESPONSIVENESS

29.1 The owner's determination of a bid's responsiveness is based on the content of the bid only. Prior to the detailed evaluation of Bids, the Employer will determine whether each Bid: -

- (a) Meets the "Bid Evaluation Criteria" of the Bidding Documents;
- (b) Has been properly signed;
- (c) Is accompanied by the required 'Earnest Money / Bid Security' (if applicable);
- (d) Is substantially responsive to the requirements of the Bidding Documents; and
- (e) Provides any clarification and/or substantiation that the Employer may require to determine responsiveness pursuant to "ITB: Clause-29.2"

29.2 A substantially responsive Bid is one which conforms to all the terms, conditions and specifications of the Bidding Documents without material deviations or reservations or omissions for this purpose employer defines the foregoing terms below: -

- a) "Deviation" is departure from the requirement specified in the tender documents.
- b) "Reservation" is the setting of limiting conditions or withholding from complete acceptance of the requirement in the tender documents.
- c) "Omission" is the failure to submit part or all of the information or documentation required in the tender document.

29.3 A material deviation, reservation or omission is one that,

- a) If accepted would,
 - i) Affect in any substantial way the scope, quality, or performance of the job as specified in tender documents.
 - ii) Limit, in any substantial way, inconsistent with the Tender Document, the Employer's rights or the tenderer's obligations under the proposed Contract.
- b) If rectified, would unfairly affect the competitive position of other bidders presenting substantially responsive bids.

29.4 The employer shall examine all aspects of the bid to confirm that all requirements have been met without any material deviation reservation or omission.

29.5 If a Bid is not substantially responsive, it may be rejected by the Employer and may not subsequently be made responsive by correction or withdrawal of the of material deviation, reservation or omission.

30 CORRECTION OF ERRORS

30.1 Bids determined to be substantially responsive will be checked by the Employer for any arithmetic errors. Errors will be corrected by the Employer as follows:

- (i) When there is a difference between the rates in figures and words, the rate which corresponds to the amount worked out by the contractor (by multiplying the quantity and rate) shall be taken as correct.
- (ii) When the rate quoted by the contractor in figures and words tallies but the amount is incorrect, the rate quoted by the contractor shall be taken as correct and not the amount and the amount corrected.
- (iii) When it is not possible to ascertain the correct rate, in the manner prescribed above, the rate as quoted in words shall be adopted and the amount worked out, for comparison purposes

30.2 The amount stated in the bid will be adjusted by the Employer in accordance with the above procedure for the correction of errors. If the bidder does not accept the corrected amount of bid, its bid will be rejected, and the bid security shall be forfeited.

31 CONVERSION TO SINGLE CURRENCY FOR COMPARISON OF BIDS

Not Applicable. All bids submitted must be in the currency specified at clause 14 of ITB.

32 EVALUATION AND COMPARISON OF BIDS

Bid shall be evaluated as per evaluation criteria mentioned in **Section-II (BEC and Award Methodology)** of bidding documents. The employer shall only use the criteria and methodology indicated in Section-II of bidding documents. No other criteria/ methodology shall be permitted. In case any bidder doesn't charge GST, then evaluation shall be carried out considering the appropriate % of GST. However, payment shall be made without GST as per rate quoted by bidder.

33 COMPENSATION FOR EXTENDED STAY

VOID

[F] – AWARD OF CONTRACT

35 AWARDS

Subject to "ITB: Clause-29", GNGPL will award the Contract to the successful Bidder whose Bid has been determined to be substantially responsive and has been determined as the **LOWEST** provided that bidder, is determined to be qualified to satisfactorily perform the Contract (As per BEC and award methodology of tender).

36 NOTIFICATION OF AWARD / FAX OF ACCEPTANCE

- 36.1 Prior to the expiry of 'Period of Bid Validity', GNGPL will notify the successful Bidder in writing, in the form of "Notification of Award" / "Fax of Intent [FOI]" / "Fax of Acceptance [FOA]", through fax/e-mail, that his Bid has been accepted. The notification of award / Fax of Intent will constitute the formation of the Contract.
- 36.2 Contract period shall commence from the date of "Notification of Award" or as mentioned in the Notification of Award. The "Notification of Award" will constitute the formation of a Contract, until the Contract has been affected pursuant to signing of Contract as per "ITB: Clause-37".

Upon the successful Bidder's / Contractor's furnishing of 'Contract Performance Security / Security Deposit', pursuant to "ITB: Clause-38", GNGPL will promptly discharge his 'Earnest Money / Bid Security', pursuant to "ITB: Clause-16"

37 SIGNING OF AGREEMENT

- 37.1 GNGPL will award the Contract to the successful Bidder, who, within 'fifteen [15] days' of receipt of the same, shall sign and return the acknowledged copy to GNGPL.
- 37.2 The successful Bidder/Contractor shall be required to execute an 'Agreement' in the proforma given in this Bidding Document on a 'non-judicial stamp paper' of appropriate value [cost of the 'stamp-paper' shall be borne by the successful Bidder/Contractor] and of 'Goa state' only, within 'fifteen [15] days' of receipt of the "Letter of Acceptance [LOA]" of the Tender by the successful Bidder/Contractor failure on the part of the successful Bidder/Contractor to sign the 'Agreement' within the above stipulated period, shall constitute sufficient grounds for forfeiture of EMD/Security Deposit.

38 CONTRACT PERFORMANCE SECURITY / SECURITY DEPOSIT

- 38.1 Within 30 days of the receipt of the notification of award/ Fax of Acceptance from GNGPL, the successful bidder shall furnish the contract performance security/Guarantee in accordance with of Special Conditions of the Contract.(SCC) CPBG shall be valid till three (3) months beyond the expiry of defect liability period after successful completion of entire work.

38.2 CPBG shall be retained at owner's end till completion of contract period (i.e., till completion of defect liability period against all the supplies awarded against this tender).

Bank Guarantee towards performance security/ security deposit shall be from any Indian scheduled bank or a branch of an international bank situated in India and registered with Reserve bank of India as scheduled foreign bank in case of Indian bidder as well as foreign bidder. However, in case of bank guarantees from banks other than the Nationalized Indian banks, the bank must be a commercial bank having net worth in excess of Rs 100 crores and a declaration to this effect should be made by such commercial bank either in the Bank Guarantee itself or separately on its letterhead. This bank guarantee shall be valid for a period as three months beyond the DLP specified in Bid Data Sheet.

38.3 Failure of the successful bidder to comply with the requirements of this article shall constitute sufficient grounds for the annulment of the award and forfeiture of the bid security.

38.4 Contract value for security Deposit/ Performance Guarantee purpose shall be excluding final GST.

38.5 There is no exemption to PSUs/ MSEs including SSI units from submission of Security Deposit/ Contract Performance Bank Guarantee (CPBG).

39 AHR ITEMS

In items rate contract where the quoted rates for the items exceed 50% of the estimate rates, such items will be considered as Abnormally High Rates (AHR) Items and payment of AHR items beyond the SOR stipulated quantities shall be made at the lowest amongst the following rates:

- I) Rates as per SOR, quoted by the Contractor/Bidder.
- I) Rate of the item, which shall be derived as follows:
 - a. Based on rates of Machine and labour as available from the contract (which includes contractor's supervision, profit, overheads and other expenses).
 - b. In case rates are not available in the contract, rates will be calculated based on prevailing market rates of machine, material and labour plus 15% to cover contractor's supervision profit, overhead & other expenses.

40 PUBLIC PROCUREMENT POLICY FOR MICRO AND SMALL ENTERPRISES (REFER BDS FOR APPLICABILITY OF THIS CLAUSE)

40.1 Following provision has been incorporated in tender for MSEs, in line with notification of Government of India, vide Gazette of India No. 503 dated 26.03.2012 proclaiming the Public Procurement Policy on procurement of goods and services from Micro and Small Enterprises (MSEs)

- i) Issue of tender document to MSEs free of cost.
- ii) Exemption to MSEs from payment of EMD/Bid Security.

AS THIS TENDER IS NON-SPLITABLE OR NON- DIVIDABLE (SPECIFIED IN BID DATA SHEET.

40.2 The MSEs owned by SC/ST entrepreneurs shall mean:-

- a) In case of proprietary MSE, Proprietor(s) shall be SC/ST.
- b) In case of partnership MSE, the SC/ST partners shall be holding at least 51% share in the unit
- c) In case of private Limited Companies, at least 51%share is held by SC/ST. If the MSE is owned by SC/ST entrepreneurs, the bidder shall furnish appropriate documentary evidence in this regard.

40.3 The Public Procurement Policy for MSEs is meant for procurement of only goods produced & Services rendered by MSEs and hence shall not be applicable for works contracts

In case bidder is a Micro or Small Enterprise under the Micro, Small and Medium Enterprises Development Act, 2006, the bidder shall submit the following :

- a) Documentary evidence that the bidder is a Micro or Small Enterprises registered with District Industries Centers or Khadi and Village Industries National Small Industries Corporation or Directorate of Handicrafts and Handloom or any other body specified by Ministry of Micro, Small and Medium Enterprises
- b) If the MSE is owned by SC/ST Entrepreneurs, the bidder shall furnish appropriate documentary evidence in this regard.

The above documents submitted by the bidder shall be duly certified by the Chartered Accountant (not being an employee or a Director or not having any interest in the bidder's company/firm) and notary public with legible stamp.

If the bidder does not provide the above confirmation or appropriate document or any evidence, then it will be presumed that they do not qualify for any preference admissible in the Public Procurement Policy (PPP) 2012.

40.4 If against an order placed by GNGPL, successful bidder(s) (other than Micro/Small Enterprise) is procuring material/services from their sub-vendor who is a Micro or Small Enterprise registered with District Industries Centers or Khadi and Village Industries Commission or Khadi and Village Industries Board or Coir Board or National Small Industries Corporation or Directorate of Handicrafts and Handloom or having Udyog Aadhar Memorandum or any other body specified by Ministry of Micro, Small and Medium Enterprises with prior consent in writing of the purchasing authority/Engineer-in-charge, the details like Name, Registration No., Address, Contact No. details of material & value of procurement made, etc. of such Enterprises shall be furnished by the successful bidder at the time of submission of invoice/Bill.

41 VENDOR PERFORMANCE EVALUATION

SHALL BE AS STIPULATED IN ANNEXURE IV OF SECTION: V OF TENDER ATTACHED HEREWITH.

42 INCOME TAX & CORPORATE TAX

- 42.1 Income tax deduction shall be made from all payments made to the contractor as per the rules and regulations in force and in accordance with the Income Tax Act prevailing from time to time.
- 42.2 Corporate Tax liability, if any, shall be to the contractor's account.

43 SETTLEMENT OF DISPUTES BETWEEN GOVERNMENT DEPARTMENT AND ANOTHER AND ONE GOVERNMENT DEPARTMENT AND PUBLIC ENTERPRISE AND ONE PUBLIC ENTERPRISE AND ANOTHER

In the event of any dispute or difference relating to the interpretation and application of the provisions of the contracts, such dispute or difference shall be referred by either party for Arbitration to the sole Arbitrator in the Department of Public Enterprises to be nominated by the Secretary to the Government of India in-charge of the Department of Public Enterprises. The Arbitration and Conciliation Act, 1996 shall not be applicable to arbitrator under this clause. The award of the Arbitrator shall be binding upon the parties to the dispute, provided, however, any party aggrieved by such award may make a further reference for setting aside or revision of the award to the Law Secretary, Department of Legal Affairs, Ministry of Law & Justice, Government of India. Upon such reference the dispute shall be decided by the Law Secretary or the Special Secretary / Additional Secretary, when so authorized by the Law Secretary, whose decision shall bind the Parties finally and conclusively. The parties to the dispute will share equally the cost of arbitration as intimated by the Arbitrator.

BIDDING DATA SHEET (BDS)

ITB TO BE READ IN CONJUNCTION WITH THE FOLLOWING:

A. GENERAL	
	Description
	The Invitation for Bids/ Tender no is: GNGPL/C&P/T-34
	The Employer/Owner is: M/S. GOA NATURAL GAS PVT. LTD. (GNGPL)
	The name of the Works/Services to be performed is Hiring of Operation & Maintenance Services for City Gas Distribution Project of M/s Goa Natural Gas Pvt Ltd. In North Goa GA
B. BIDDING DOCUMENT	
	Description
IFB clause	
2-K	For clarification purposes only, the communication address is: Attention: Mr. Nilesh Nagawade, Sr.Manager, Street Address: GNGPL, 33 Rajan Villa. Journalist Colony. Porvorim. Goa-403521. Country: India
C. PREPARATION OF BIDS	
	Description
ITB clause	
14	The currency of the Bid shall be INR
15	The bid validity period shall be 03 (THREE) MONTHS from final 'Bid Due Date'.
D. SUBMISSION AND OPENING OF BIDS	
	Description
ITB clause	
18	In addition to the original of the Bid, the number of copies required is NIL . Not applicable in case of e-tendering.
18.3	The E-Tender No. of this bidding process is: Not Applicable
21.3	For bid submission purposes only, the Owner's address is: Attention: Mr. Nilesh Nagawade. Senior Manager GNGPL, 33 Rajan Villa. Journalist Colony. Porvorim. Goa-403521. Country: India
26	The bid opening shall take place at: Goa Natural Gas Pvt Ltd. Plot No. 33 Rajan Villa. Journalist Colony. Porvorim. Goa-403521. Country: India

E. EVALUATION, AND COMPARISON OF BIDS	
ITB clause	Description
32	<i>EVALUATION METHODOLOGY IS MENTIONED IN SECTION-II (ITB).</i>
33	Compensation for Extended Stay: <i>NOT APPLICABLE</i>
F. AWARD OF CONTRACT	
ITB clause	Description
37	State of which stamp paper is required for Contract Agreement: <i>GOA.</i>
38	Contract Performance Security/ Security Deposit: <i>APPLICABLE AS PER SCC</i>
40	Public Procurement policy for MSEs: <i>Since this is works contract, award preference shall not be given.</i> <i>THIS TENDER IS NON-SPLIT ABLE OR NOT-DIVISIBLE.</i>
39	Provision of AHR Item: <i>APPLICABLE</i>
	<i>Integrity Pact is APPLICABLE</i>
Clause no. 27.3 of GCC	Bonus for Early Completion: <i>NOT APPLICABLE</i>

SECTION-III

SPECIAL CONDITION OF CONTRACT (SCC)

SPECIAL CONDITIONS OF THE CONTRACT (SCC)

PART-I of SCC

The following Special Conditions of Contract shall supplement the General Conditions of Contract. Whenever there is a conflict, the provisions herein shall prevail over those in the General Conditions of the Contract. The corresponding clause number of the GCC is indicated in parentheses.

GENERAL

Special conditions of contract (SCC) shall be read in conjunction with the General Conditions of Contract (GCC). Schedule of rates, specifications of work, drawings and any other document forming part of this contract wherever the context so requires.

Notwithstanding the sub-division of the document into these separate sections and volumes, every part of each with and into the contract so far as it may be practicable to do so.

Where any portion of the GCC is repugnant to or at variance with any provisions of the special conditions of contract, then unless a different intention appears, the provision(s) of the special conditions of contract shall be deemed to override the provision(s) of GCC only to the extent that such repugnancy of variations in the special conditions of contract are not possible of being reconciled with the provisions of GCC.

Wherever it is stated in this Bidding Document that such and such a supply is to be affected or such and such a work is to be carried out, it shall be understood that the same shall be effected/carried out by the contractor at his own cost, unless a different intention is specifically and expressly stated herein or otherwise explicit from the context. Contract value (also referred to as Contract price) shall be deemed to have included such cost.

The materials, design and workmanship shall satisfy the applicable relevant Indian Standards, the job specifications stipulate requirements in addition to those contained in the standard codes and specifications, these additional requirements shall also be satisfied. In the absence of any Standard/ Specifications/codes of practice for detailed specifications covering any part of the work covered in this Bidding on the contractor.

In case of contradiction between Indian or other applicable Standards, General Conditions of Contract, Special Conditions of Contract, Specifications, drawings, Schedule of Rates, the following shall prevail in order of precedence:

- i) Letter of acceptance along with statement of Agreed variations.
- ii) Fax / Letter of Intent / Fax of Acceptance
- iii) Schedule of Rates as enclosures to letter of acceptance
- iv) Job / Particular Specifications
- v) Drawings
- vi) Technical / Material Specifications

- vii) Special Conditions of Contract
- viii) General Conditions of Contract
- ix) Indian Standards
- x) Other Applicable Standards

It will be contractor's responsibility to bring to the notice of Engineer-in-charge any irreconcilable conflict in the contract documents before starting the work(s) of making the supply with reference which the conflict exists.

In the absence of any specifications covering any material, design of work(s) in the same shall be performed / supplies / executed in accordance with Standards Engineering Practice as per the instructions / directions of the Engineer-in-charge, which will be binding on the Contractor.

Owner's representative means authorized representative of Owner (i.e., M/s GNGPL.) and / or Consultant (i.e., M/s VCS Quality Services Pvt Ltd)

Wherever it is mentioned in the specification that the Contractor shall perform certain work or provide certain facilities as per the best industrial practices, it is understood that the Contractor shall do so at his cost and the value of contract shall be deemed to have included cost of such performance and provisions, so mentioned.

The materials, equipment, and workmanship shall satisfy the applicable standards, specifications contained herein and codes referred to where the Technical Specifications stipulate requirements in addition to those contained in the Standard Codes and Specifications, those additional requirements shall also be satisfied.

Prior to submitting the bids, it shall be assumed that the Contractor is fully familiar with the Site Conditions and has conducted thorough studies of the Site with regards Site Conditions, Climatic Conditions, local Labor laws, equipment availability, transport and Communication facilities, space for control rooms and all other factors, facilities and things whatsoever necessary or relevant for performing the Works.

The Contractor is advised to visit and examine the site of works and its surroundings and obtain for himself on his own responsibility, all information that may be necessary for preparing of the bid and entering into contract. The cost of visiting the site shall be at Contractor's own expenses.

The Contractor or any of its personnel or agents will be granted permission by the Employer to enter upon its premises and land for the purpose of such visits, but only upon the express condition that the Contractor, its personnel, and agents will release and indemnify the Employer and its personnel and agents from and against all liabilities in respect thereof, and will be responsible for death or personal injury, loss of or damage to property, and any loss, damage, costs, and expenses incurred as a result of the inspection.

1 SCOPE OF WORK: -

Scope of work shall be as detailed in Part -II of SCC and SOR of this tender Document

Outline of the Contract:

The entire work of providing O&M Services shall be Annual Maintenance Contract for 1 year and extendable to 1 more year at same rates, terms & condition. The major works under this AMC shall be hiring of O&M Offices, providing services for various O&M office on round the clock basis, maintenance of CGD equipment viz. DRS, MRS etc., effective patrolling of entire Steel & MDPE pipeline network with GPS tracking system, safeguarding the Steel/MDPE network from Third Party damages, immediate restoration of damaged portion of Steel/MDPE network, attending complaints of domestic, industrial & commercial customers, conversion of LPG stoves, installation of GI/Cu pipes, installation of meters & regulators and maintenance of the same etc. The detailed scope work is included along with Schedule of Rates

The contractor shall be required to provide the services of the O&M office based on the instruction of the Engineer-in charge (EIC) or his representative. The quantities given in SOR are tentative which may vary as per requirement of GNGPL. However, payment shall be made for actual work done basis.

2 CONTRACT PERIOD: -

The contract for Operations & Maintenance of CGD Network in Geographical area of North Goa and Ponda shall be Annual Maintenance Contract (AMC) for period of 1 year which can be extended to 1 more year on mutual consent at same rates, terms & condition.

3 MOBILIZATION PERIOD:-

Mobilization period shall be Fifteen (15) days from the date of FOA. The successful Contractor shall mobilize the required manpower along with tools/tackles etc. for O&M of the network within mobilization period.

All expenses towards mobilization at site and de-mobilization of equipment, workforce, material and clearing the site etc. shall be deemed included in the price quoted by the contractor and no extra payment on such expenses shall be entertained.

No mobilization advance is payable to contractor for the said work.

The contractor shall make his own arrangement for removal of old as well as unused material from work site to the place indicated by the EIC, after completion of work

3 TERMS OF PAYMENT: -

Monthly running bills to be submitted by the Agency/Contractor for verification and certification by Engineer-In-charge (EIC) or by nominated Authorized representative of EIC.

a. The following documents should be submitted along with the bills to GNGPL through Site in- charge / Engineer-In-charge (EIC) for the release of payment by Finance Department of GNGPL. The payment will be made through e-banking system.

b. Monthly bill duly certified by the contractor or his authorized representative

c. Copy of e-banking wage sheet/bank statement duly stamped by designated bank and duly certified by the contractor or his authorized representative. Copy of Electronic Challan cum Return (ECR) and bank remittance slip for the proof of deposit of Provident Fund contribution with RPFC along with details of employees and Provident Fund A/C No. duly stamped by designated bank.

d. Goods service tax Invoice with GST number.

e. The final bill shall be submitted by the Agency/Contractor within a month from the date of completion of the contract. No Claim Certificate, No Dues Certificate, shall be submitted by the contractor along with the Final Bill.

MEASUREMENT OF WORKS

Payment will be made based on joint measurements jointly carried out by the contractor and GNGPL, duly certified by Nominated Site-In-Charge/EIC. Linear measurements will be in hours and converted to days. Indian Standard Method of measurement (IS:1200) as last amended, shall be referred for measurement purposes wherever applicable.

4 INSTRUCTIONS TO CONTRACTORS:

The Agency / contractor shall provide, at its own costs, uniforms, to its employees and ensure that its employees, while on duty, wear such uniforms. The dress code (100% Cotton) for uniform shall be as prescribed by GNGPL

The Agency / contractor shall be responsible for ensuring that its employees conduct themselves in a proper manner and are courteous to customers. The Agency / contractor shall not engage or employ any person with a criminal record/ background. The Agency / contractor shall remove the employee or worker who is found guilty of misconduct or negligence while on duty or whose conduct is not in order. The decision taken by the EIC or his authorized representative shall be final & binding. The Contractor shall submit police verification of their employees within 15 days of his/her deployment.

The Agency / contractor shall take due care of the equipment installed and ensure that the same are operated by properly trained people in a prudent manner. In case of any breakdown in or damage to or defect in the equipment, the Agency / contractor shall immediately notify to the GNGPL officials and shall not operate till clearance is given by GNGPL.

The Agency / contractor shall follow the safety procedures, issued from time to time, specified by GNGPL. The Agency / contractor shall ensure full and strict compliance of the guidelines, norms, rules, stipulations etc. as may be prescribed by Petroleum & Explosives

Safety Organization (PESO) Nagpur, Chief Fire Officer (CFO), and any other statutory authorities from time to time at the Site.

If the work is to be carried out in "Restricted Area" (i.e. operating area not open for all being hazardous in nature) and Agency/Contractor shall work as per the instructions of Site Engineer/ Engineer-In-Charge

If the work is to be carried out in "Restricted Area" (i.e. operating area not open for all being hazardous in nature) and Agency/Contractor shall work as per the instructions of Site Engineer/ Engineer-In-Charge

The jobs performed under this contract shall be of WORKS in nature and supply items such as MDPE pipes, steel pipes, meter, regulator etc. shall be provided by GNGPL However, all the consumable material such as couplers, fittings, GI/Cu pipes, valves etc. required for completion of the jobs shall be provided by the Contractor

The Agency/Contractor shall arrange at his own cost the boarding, lodging & to and fro transportation for his staff/s. The contractor shall arrange suitable conveyance to the manpower deployed by him for attending various activities at each O&M office. At no point of time work should not get hampered due to mobility constraints. If any delay in responding to any complaint shall be viewed seriously and suitable penalty shall be levied on the contractor.

The Agency/Contractor shall provide proper identification cards to his personnel duly signed by the Agency/Contractor or his authorized representative. The identity cards shall be traceable with any of the Govt. issued Identity Cards for each individual.

As gas supply to customer is an essential service hence during contract period, qualified Contractor or his staff /crew cannot resort to strike or other means of agitation on any ground, which affects the operations. Any absence of crew / staff shall be viewed seriously and contract is liable to be terminated by GNGPL withholding all balance dues of contract and deposits and including encashment of performance bank guarantee.

The contractor shall open & operate Pradhan/ Mantri Insurance (Pradhan Mantri Suraksha Bima Yojana) and other statutory schemes introduced by state/central govt for the employees hired for O&M services during the contract period.

The contractor shall liaison / deal with the local authorities like police, fire brigade, affected customers or public and other concerned authorities for conducting O&M activities required for interrupted gas supply to customer.

5 CONTRACT PERFORMANCE BANK GUARANTEE/ SECURITY DEPOSIT: -

Bidder must provide Performance Guarantee as per following:-
SD/CPBG @ 10% of Annualized Order/Contract Value within 30 days of FOA/Notification of award

OR

Initial security deposit (ISD) @ 2.5% of Annualized order/Contract value to be submitted within 30 days of FOA/Notification of award and deduction @7.5% of the RA bill subsequently from RA bill till the amount of security deposit (including ISD and deducted amount) reaches 10% of Annualized Order/ Contract value

CPBG shall be valid till three (3) months beyond the expiry of defect liability period after successful completion of entire work.

Bank Guarantee towards performance security/ security deposit shall be from any Indian scheduled bank or a branch of an international bank situated in India and registered with Reserve bank of India as scheduled foreign bank in case of Indian bidder as well as foreign bidder. However, in case of bank guarantees from banks other than the Nationalized Indian banks, the bank must be a commercial bank having net worth in excess of Rs 100 crores and a declaration to this effect should be made by such commercial bank either in the Bank Guarantee itself or separately on its letterhead. This bank guarantee shall be valid for a period as three months beyond the DLP

Failure of the successful bidder to comply with the requirements of this article shall constitute sufficient grounds for the annulment of the award and forfeiture of the bid security.

Contract value for security Deposit/ Performance Guarantee purpose shall be excluding final GST.

There is no exemption to PSUs/ MSEs including SSI units from submission of Security Deposit/ Contract Performance Bank Guarantee (CPBG).

Addition to above, following will also apply: -

In the event completion of works is delayed beyond the Scheduled Completion Date for any reasons whatsoever, the Contractor shall have the validity of the guarantee suitably extended to cover the period mentioned above.

The Employer shall have an unqualified option under this guarantee to invoke the Banker's Guarantee and claim the amount there under in the event of the Contractor failing to honour any of the commitments entered into under this Contract and/or in respect of any amount due from the Contractor to the Employer/Consultant. In case Contractor fails to furnish the requisite Bank Guarantee as stipulated above, then the Employer shall have the option to terminate the Notification of Award of Work and forfeit the Bid Security/Earnest Money amount and no compensation for the works performed shall be payable upon such termination.

Upon completion of the Works as per Completion Schedule stipulated in the Contract, the above said guarantee shall be considered to constitute the Contractor's warranty/guarantee for the work done by him or for the Works supplied and their performance as per the specifications and any other conditions against this Contract. The warranty/guarantee shall remain in force for 12 months from the date of issuance of certificate of Completion and Acceptance against this Contract as per GCC. The Contractor shall also arrange for the Performance Guarantee to remain valid till expiry of 90 days after the end of Defect Liability Period /Guarantee period for entire works covered under the contract.

In the event of Completion of Project being delayed beyond the Scheduled Completion Date, the Employer may without prejudice to any other right or remedy available to the Employer, operate the Bank Guarantee to recover the Compensation for delay leviable as per Clause below. The Bank Guarantee amount shall thereupon be increased to the original amount, or the Contractor may alternatively submit a fresh Bank Guarantee for the equivalent amount of compensation for delay recovered.

The CPBG/security deposit has to cover the entire executed contract value which includes extra work also. EIC/site shall monitor the value of executed work including extra work. and once it is envisaged that total executed value is likely to burst the ceiling of contract price, the contractor shall be asked to furnish additional security deposit/ CPBG. However, as long as the CPBG/security deposit already submitted at the time of award take cares of extra work executed and the total executed value are within the contract price, additional security deposit/CPBG for each extra work shall not be asked.

6 STATUTORY APPROVALS: -

Contractor shall be responsible for obtaining approval/clearances from statutory authorities like Village Panchayat authorities, Revenue authorities, Municipal Corporation Authorities, Electricity Department, Electrical Inspectorate, Pollution control board and any other concerned authority as required and necessitated by the job.

All statutory payment/demand raised by Govt. authorities shall be paid by the GNGPL. However, liasioning for the same shall be done by contractor. No extra payment shall be made for such liasioning work.

Any changes/additions required to be made to meet the requirements of statutory authorities, shall be carried out by the contractor, within the contract price, and at no additional cost to GNGPL.

7 LIABILITY/INDEMNITY:

GNGPL shall not be liable in any manner whatsoever (including for any loss or injury caused) to the employees or workers of the Agency / contractor during the course of their employment with the Agency / contractor or thereafter and the Agency / contractor shall be solely liable to his employees or workers.

The Agency / contractor agrees to be liable for the safety and security of the equipment installed on the Site and shall ensure that, at all times, the Safety Procedures are duly followed.

The Agency / contractor shall be liable for any unauthorized act of its employees or workers and agrees to ensure that its activities are in conformity with the terms and conditions of this Contract.

The Agency / contractor shall indemnify and keep indemnified, save harmless and defend GNGPL from and against any loss, damage, claim, action, proceedings, costs, charges and expenses that may be suffered or incurred by GNGPL on account of any damage or injury to the person or property of any third party caused by any negligence or default of the

Agency / contractor or any of its employees or workers in following the Safety procedures or otherwise howsoever or on account of any acts done or performed or caused to be done or performed by its employees or workers in the course of its/their activities under this Contract.

Whenever any claim against the Contractor for payment of a sum of money arises out of or under the contract, GNGPL shall be entitled to recover such sum by appropriating, in part or whole part of the security. In the event of security being insufficient or if no security has been taken from the Contractor then the balance or the total sum recoverable, as the case may be, shall be deducted from any sum then due or which at any time thereafter may become due from the contractor under this or any other contract with the company should this sum be not sufficient to cover the full amount recoverable, the contractor shall pay to the GNGPL on demand the balance remaining due.

Contractor shall accept full and exclusive liability for the compliance with all obligations imposed and further agrees to defend, indemnify and hold GNGPL harmless for any liability or penalty which may be imposed by the Central, State, Local authority also from all claims, suits or proceedings that may be brought against the GNGPL arising under growing out of or by reason of the work provided for may by this contract whether brought by employee of the contractor by third parties or by Central Government , State Government of Local authority for the following acts and liabilities

- i. Workmen compensation & Employer's insurance.
- ii. Accident or injury to workmen.
- iii. Damage to GNGPL property or to any person or third party.
- iv. Payment of wages act.
- v. Any other insurance required law or regulations.

Contractor must indemnify GNGPL / GNGPL's employees against any liquidated damages incurred as the principal employer for any failure of contractor to honor various central / state / local self-body laws / enactments in this respect.

Contractor himself shall be fully and exclusively responsible for any damage to the equipment or any personal injury to operator or any other person in the employment of the contractor, occupant or any property.

Contractor will be solely responsible for any consequences under laws arising out of any accidents caused to property / persons. The contractor shall also be responsible for any claim / compensation that arises due to damage / cause of injuries / disabilities / death etc. during the contract period GNGPL will not be responsible for any claim / compensation that arises due to damages / injuries under any circumstances in which the equipment is engaged for GNGPL duty.

8 WORK SPECIFICATIONS AND STANDARDS:

All the specifications for the work shall be as per 'Scope of Work & Technical Specifications' and 'SOR', which are self-explanatory. However, wherever required, concerned Bureau of Indian Standards shall be referred and the decision of the EIC shall be final and binding on the contractor.

The job shall conform to the Indian Electricity Rules-1956, Indian Electricity (Supply Act) calculations for the Electrical Buildings-1959 of the Insurance Association, Indian Electricity

Act, relevant Indian Standard Specifications, and Codes of Practice, as modified till date, & CPWD Specifications, Petroleum & Explosives Safety Organization (PESO) Nagpur, Chief Fire Officer (CFO), and any other statutory authorities from time to time at the Site as applicable. Any other Standard not mentioned above, but considered necessary for the satisfactory performance of the job shall also be applicable

Contractor shall observe in addition to Codes specified in respective specification, Technical Specifications, Drawings (tentative), Job Specifications, all national and local laws, ordinances, rules and regulations and requirements pertaining to the work and shall be responsible for extra costs arising from violations of the same. The contractor shall carry out the work in accordance with the requirement of latest relevant applicable standards, this specification, Latest PNGRB Guidelines, ASME B31.8 - Gas Transmission and Distribution Piping Systems, and the American Gas Association Document - Purging Principles and Practice. and GNGPL's approved procedures. Should the contractor find any discrepancy, ambiguity or conflict in or between any of the Standards and the contract documents, then this should be promptly referred to the Engineer-in-Charge (EIC) for his decision, which shall be considered binding on the contractor

Whenever it is mentioned in the specification that the contractor shall perform and execute the certain work or provide certain facilities, it is understood that the contractor shall do at his own cost and the Contract price shall be deemed to have included cost of such performances and provisions, so mentioned.

All the Supply Material shall be from the approved vendor's list only. The Approved Vendor List is attached. Any supply material must confirm to the applicable Indian Standards.

9 WORKING HOURS: -

Depending upon the requirements, time schedule/ drawn up programs and the target set to complete the job in time the works may have to continue beyond normal working hours to the extent of round the clock and on holidays also for which no extra claim shall be entertained.

10 ADDITIONAL WORKS/EXTRA WORKS: -

Owner reserve their right to execute any additional works/ extra works, during the execution of Work, either by themselves or by appointing any other agency, even though such works are incidental to and necessary for the completion of works awarded to the Contractor. In the event of such decisions taken by Owner, Contractor is required to extend necessary cooperation and act as per the instructions of Engineer-in-Charge

11 COMPENSATIONS FOR IDLE TIME: -

The owner shall make every reasonable effort to have the materials and working front available so as not to delay laying activities. No idle time claim shall be entertained under any circumstances.

12 RULES AND REGULATIONS: -

Contractor shall observe in addition to Codes specified in respective specification, all national and local laws, ordinances, rules and regulations and requirements pertaining to the work and shall be responsible for extra costs arising from violations of the same.

13 PROCEDURES: -

Various procedures and method statements to be adopted by Contractor during the construction as required in the respective specifications shall be submitted to Engineer-in-Charge in due time for approval. No construction activity shall commence unless approved by Engineer-in-Charge in writing.

14 DRAWINGS AND DOCUMENTS: -

The drawings accompanying the bid document (if any) are of indicative nature and issued for bidding purpose only. Purpose of these drawing is to enable the bidder to make an offer in line with the requirements of the Employer/Consultant. However, no extra claim whatsoever, shall be entertained for variation in the "Approved for Construction" and "Bid document drawings" regarding any changes/units. Construction shall be as per drawings/specifications issued/approved by the Engineer-in-Charge during the course of execution of work. Detailed construction drawings (wherever required) on the basis of which actual execution of work is to proceed will be prepared by the contractor.

The drawings and documents to be submitted by the Contractor to Employer/Consultant after award of the work as per the requirements enlisted in the bidding document shall be for Employer/Consultant's review, information and record. The Contractor shall ensure that drawings and documents submitted to Employer/Consultant are accompanied by relevant calculations, data as required and essential for review of the document/ drawings. VCS shall review the drawings/ documents within two weeks from the date of submission provided the same are accompanied by relevant calculations, data as required and essential for review.

All documents and drawings including those of Contractors sub-vendor's manufacturers etc. shall be submitted to Employer/Consultant after having been fully vetted in detail, approved and co-opted by the Contractor & shall bear Contractor seal/ certifications to this effect. All documents/drawings & submissions made to Employer/Consultant without compliance to this requirement will not be acceptable and the delay & liability owing to this shall be to the Contractor's account.

The review of documents and drawings by Employer/Consultant shall not absolve Contractor from his responsibility to meet the requirements of specifications, drawings etc. and liabilities for mistakes and deviations. Upon receiving the comments on the drawing/documents reviewed by Employer/Consultant, Contractor shall incorporate the comments as required and ensure their compliance.

Copies of all detailed working drawing relating to the works shall be kept at the contractors' office at the site and shall be made available to the Engineer- in-charge/ Employer/Consultant at any time during execution of the contract. However, no extra claim what so ever shall be entertained for any variation in the "approved/issued for construction drawings" and "tender drawings" regarding any changes/units unless otherwise agreed.

The Contractor shall rectify any inaccuracies, errors and non-compliance to contractual

requirements. Any delay occurring on this shall not construe a reason for delay/ extension.

15 HEALTH SAFETY AND ENVIRONMENT (HSE) MANAGEMENT; -

After the award of the contract, detailed Health, Safety and Environment (HSE) program to be followed for execution of contract under various divisions of works will be mutually discussed and agreed between Contractors, Client & PMC.

The Contractor shall establish document and maintain an effective Health, Safety and Environment (HSE) management system.

In case contractor fails to follow the instructions of Engineer-in-charge with respect to above clauses, next payment due to him shall not be released unless until he complies with the instructions to the full satisfaction of Engineer-in-charge.

The Contractor shall adhere to the Health, Safety and Environment (HSE) management system as per GNGPL. Specification and General Conditions of Contract.

It will be the Contractor's responsibility to acquaint his site staff and operatives of all current safety legislation, statutory requirements and GNGPL.'s safety standards. In addition, and before any work takes place all the Contractor's operatives shall be given training in site safety by the trained person under supervision of GNGPL. If the Contractor wishes to start any new operatives on site, he must first inform the SE, who will arrange for such training to be arranged.

16 ISSUE AND RECONCILIATION OF MATERIAL (IF ANY): -

Conditions for Issue of Materials

Whenever any material is issued by Owner, following conditions for issue of material in addition to other conditions specified in the contract shall be applicable.

Necessary indents will have to be raised by the Contractor as per procedure laid down by the Engineer-in-charge from time to time, when he requires the above material for incorporation in permanent works.

Materials will be issued only for permanent works and not for temporary works, enabling works etc. unless specifically approved by the Engineer-in-charge and the same shall not be taken into account for the purpose of materials reconciliation.

The contractor shall bear all other cost including lifting, carting from issue points to work site/ contractor's store, custody and handling etc. and return of surplus/ serviceable scrap materials to Owner's storage points to be designated by the Engineer-in-charge etc. No separate payment for such expenditure will be made.

No material shall be allowed to be taken outside the GNGPL store without a gate pass.

The contractor shall be responsible for proper storage, preservation and watch & ward of the materials.

Reconciliation of Owner supplied materials

Every month, the contractor shall submit an account for all materials issued by Owner in the proforma prescribed by the Engineer-in-charge. On completion of the work the contractor shall submit "Material Appropriation Statement" for all materials issued by the Owner in the proforma prescribed by the Engineer-in-charge.

Waste materials like part lengths of pipes and other partly used items are the property of GNGPL and must be returned to the store with the appropriate documentation so that they can be considered as part of the material reconciliation.

Item	Unaccountable	Scrap
Regulators, meters	0%	0%
GI Service Pipes	2%	2% (less than 0.5 mtrs)
PE Pipes	2%	2% (less than 2.0 mtrs)
Consumables	Discretionary	-

Unaccountable wastage/ scrap shall be at actual as per site assessment subject to maximum as stated above.

The percentage allowance shall be accounted on the basis of final measurement book.

All unused, scrap materials and salvageable materials shall be the property of the Owner and shall be returned by the Contractor category-wise at his cost to the Owner's designated store yard(s). In case the Contractor fails to do so/ or exceeds the limits of allowances specified above for scrap/ serviceable materials, then recovery for such quantities not returned as well as returned in excess of permitted limit by the Contractor will be done at the penal rate i.e., 125% of landed cost at the time of final bill/ closing of contract by Engineer-in-charge shall be affected from the Contractor's bill(s) or from any other dues of the Contractor to the Owner. Contractor shall be responsible for the adjustment/ weighment/ measurement of the surplus materials to be returned to the store. Contractor shall also be responsible for suitable segregation of returned materials into separate stacks of serviceable and scrap materials.

Wherever certain material is covered under Contractor's scope of supply whether part or in full for any item of work covered under SOR, no allowance towards wastage/ scrap etc. shall be accounted for during execution stage

17 CONTRACTOR'S SCOPE OF SUPPLY:

Contractor shall provide to their staff appropriate tools, tackles, equipment, measuring instruments and vehicle for proper execution of the job, as detailed in the Scope of Work - Technical of the tender document. It shall be the contractor's responsibility to provide and maintain all the tools & tackles in good working condition.

he contractor shall also remain in touch with the EIC for knowing the requirement of jobs, and will accordingly arrange for deployment of personnel as per the requirement.

Contractor should follow all security rules and regulations of GNGPL. Contractor shall provide all safety gears for safe working to his personnel such as safety shoes, helmets, gloves etc. at his own cost. Contract personnel without wearing prescribed uniform and safety shoes shall not be allowed to work at site.

18 GOVERNMENT OF INDIA NOT LIABLE: -

It is expressly understood and agreed by and between the Contractor and the Employer that the Employer is entering into this agreement solely on its own behalf and not on behalf of any other person or entity. In particular, it is expressly understood and agreed that the Government of India is not a party to this agreement and has no liabilities, obligations or rights there under. It is expressly understood and agreed that the Employer is an independent legal entity with power and authority to enter into contract, solely in its own behalf under the applicable laws of India and general principal of Contract Law. The Contractor expressly agrees, acknowledges and understands that the Employer is not an agent, representative or delegate of Govt. of India. It is further understood and agreed that the Govt. of India is not and shall not be liable for any acts, omissions, commissions, breaches or other wrongs arising out of the contract. Accordingly, contractor hereby expressly waives, releases and foregoes any and all actions or claims, including cross claims, impleader claims or counter claims against the Govt. of India arising out of this contract and covenants not to sue to Govt. of India as to any manner, claim, cause of action or thing whatsoever arising of or under this agreement.

19 LIMITATION OF LIABILITY: -

The final payment by the Employer in pursuance of the Contract terms shall not mean release of the Contractor from all of his liabilities under the Contract. The Contractor shall be liable and committed under this contract to fulfil all his liabilities and responsibilities, till the time of release of contract performance guarantee by the Employer.

20 INCOME TAX & CORPORATE TAX: -

Income Tax deductions shall be made from all payments made to the Contractor as per the rules and regulations in force in accordance with the Income Tax Act prevailing from time to time.

Corporate Tax liability, if any, shall be to the contractor's account.

Works Contract tax/ VAT as may be applicable shall be deducted as per the trade tax act.

21 FIRM PRICES: -

The quoted prices shall be firm and shall not subjected to price escalation till the work awarded during the validity of this contract period is completed in all respects.

22 PROVIDENT FUND ACT: -

The Contractor shall strictly comply with the provisions of Employees Provident Fund Act and register themselves with RPFC before commencing work. The Contractor shall deposit Employees and Employers contributions to the RPFC every month. The Contractor shall furnish along with each running bill, the challan/ receipt for the payment made to the RPFC for the preceding months.

23 COORDINATION WITH OTHER AGENCIES: -

Work shall be carried out in such a manner that the work of other agencies operating at the site is not hampered due to any action of the Contractor. Proper coordination with other agencies will be Contractor's responsibility. In case of any dispute, the decision of Engineer-in-Charge shall be final and binding on the Contractor.

24 ABNORMALLY HIGH RATED ITEMS (AHR ITEMS):-

"In items rate contract where the quoted rates for the items exceed 50% of the owners/ estimated rates, such items will be considered as Abnormally High Rates Items (AHR) and payment of AHR items beyond the SOR stipulated quantities shall be made at the least of the following rates:

1. Rates as per SOR, quoted by the Contractor.
2. Rate of the item, which shall be derived as follows:
 - a) Based on rates of machine and labour as available from the contract (which includes contractor's supervision, profit, overheads and other expenses).
 - b) In case rates are not available in the contract, rates will be calculated based on prevailing market rates of machine, material and labour plus 15% to cover contractor's supervision profit, overhead & other expenses.

25 COMPLIANCE WITH LAWS: -

The Contractor shall abide by all applicable rules, regulations, statutes, laws governing the performance of works in India, including but not limited to the following:

- i) Contract Labour (Regulation & Abolition) Act 1970 & the centre rules, 1971 framed there under.
- ii) Payment of Wages Act.
- iii) Minimum Wages Act.
- iv) Employer's Liability Act.
- v) Factory Act.
- vi) Apprentices Act.
- vii) Workman's Compensation Act.
- viii) Industrial Dispute Act.
- ix) Environment Protection Act.

- x) Wild life Act.
- xi) Maritime Act.
- xii) Any other Statute, Act, Law as may be applicable.
- xiii) PNGRB Act.

26 SUB-LETTING OF WORKS: -

The contractor shall not, save with previous consent in writing of the Engineer-in-charge, sublet, transfer or assign the contract or any part thereof or interest therein or benefit or advantage thereof in any manner whatsoever. Provided, nevertheless, that any such consent shall not relieve the contractor from any obligation, duty or responsibility under the contract.

However, subletting of WHOLE WORKS is prohibited. Vendor/ Contractor shall submit undertaking to this effect along with each invoice/ bill.

27 BONUS FOR EARLY COMPLETION: -

Bonus for early completion shall not be applicable in this Contract.

28 JOINTS MEASUREMENT OF WORK EXECUTED, BILLING, INVOICE AND PAYMENTS: -

Measurement shall be recorded as per the methods of measurement spelt out in Specification/Contract Documents/ Procedure of GNGPL.

29 TERMINATION OF CONTRACT: -

No additional charges, other than the quoted rates and applicable taxes, shall be paid to the Agency during the contract period except statutory variation in service tax during the contract period. The contract will be for a period of one (1) year from the date of issuance of LOA/WO or from the date specified in the LOA/WO, after which the contract period can be further extended up to one year on the same terms and conditions, at the sole discretion of GNGPL.

GNGPL reserves the right to terminate the Contract either in part or in full without assigning any reason thereof. Engineer-In-Charge shall in such an event give thirty (30) days' notice in writing to the Agency of its decision to do so. Agency upon receipt of such notice discontinue the work. In the event of such termination, Agency shall be paid for the actual time performed and service provided till the date specified in the notice.

Agency shall in no case lease/ transfer/ sublet/ appoint caretaker for services and the personnel to be deployed for carrying out the contractual job.

30 PRICE BASIS: -

The quoted rate shall be firm and valid till the complete execution of the order and also for the extension periods. No escalation on what-so-ever account shall be paid under this

contract.

The rate should be quoted in the Schedule of Rates as enclosed.

Bidders are advised in their own interest to visit office and ascertain the conditions and quantum of work before quoting.

Agency should take care of GST (if applicable) while quoting rates and should separately indicate rate of GST to be charged.

The rate quoted by the Agency shall be all inclusive for provisions of all incidental expenses necessary for proper execution and completion of work in full in accordance with the Terms & Conditions of the Bid Documents.

31 GOODS & SERVICE TAX: -

Please note that responsibility of payment of GST lies with Agency only.

The bidder shall furnish copy of GST registration along with the offer wherever applicable. Alternatively, bidder shall furnish the same within one month from the date of issue of Letter of Award or along with first Invoice. In case GST is applicable for the tendered work, Agency shall claim the GST indicating rate of abatement/deduction allowed as per GST act in the first invoice itself.

In case of statutory variation in GST/statutory variation in GST, should be raised subsequent months from the date of issue of Govt. Notification for payment of differential GST amount. In case such claim is not raised within specified period of two months, claim shall not be entertained for payment of arrear.

32 NOTES TO SCHEDULE OF RATES (SOR): -

The quantities stated in SOR are tentative and may vary considerably on ± side depending upon site condition, methodology adopted as per site requirement. The payment will be made as per actual certified Measurement at site and as instructed by EIC.

Any other materials & activities not mentioned/covered in SOR, but otherwise required for satisfactory completion/safety of work as defined in tender has to be supplied /done by contractor with in the specified schedule at no extra cost to owner.

In case quantity exceeds the SOR qty., contractor shall execute / supply material as per the requirement on the same rates quoted in SOR

All items of work in the "SOR" shall be carried out as per the specifications, relevant codes, drawings and instructions of the EIC and the quoted rates are deemed to be inclusive of all materials, consumables, Labor, supervision, tools & tackles, cost of various

tests, inspections as well as preparatory, incidental, intermediate /auxiliary / ancillary or enabling works.

In case of Urgency / Breakdowns of System, EIC can direct the contractor to procure and install spares / other services for bringing the systems to normalcy. In case such spares / services are not covered in the SOR item, payment shall be made at the market rates / Invoice Value from the Equipment Manufacturer + additional 10% as administrative charges.

The Contractors are to quote for all the SOR items for entire Quantity and entire scope of work.

If the awarded Contractors could not perform the jobs as per the scope, the same shall be executed by any of the agency at the risk & cost of the non performing contractor and the expenses towards these shall be recovered including 15% of over heads.

33 PAYMENT FOR EXTRA ITEMS WHICH ARE NOT COVERED IN SOR:

If item is not covered in the SOR and needs to be executed for the completion of the work, the payment shall be made as per following:

- 1) Tax paid invoice + 10 % CP
- 2) Rate analysis based on material, Manpower and machinery consumption + 10% CP

The decision of EIC shall be final and binding to the contractor

34 DAMAGE OF EXISTING SYSTEM AND TO THE PERSONNEL:

The Job must be carried with utmost safety and GNGPL equipment should not get disturbed / affected due to execution of jobs by the Contractor. Care should be taken for the existing system. In case of damage to any existing system or equipment resulting out of the execution of the jobs under this contract, contractor would be held responsible and the affected equipment / system must be restored to normalcy by the contractor. GNGPL reserves the right to get the job done by other agencies at the risk and cost of the contractor if he fails to take corrective actions for the damaged /affected systems and shall deduct necessary amount from contractor's bills for such rectification jobs.

The Job must be carried with utmost safety and GNGPL equipment should not get disturbed / affected due to execution of jobs by the Contractor. Care should be taken for the existing system. In case of damage to any existing system or equipment resulting out of the execution of the jobs under this contract, contractor would be held responsible and the affected equipment / system must be restored to normalcy by the contractor. GNGPL reserves the right to get the job done by other agencies at the risk and cost of the contractor if he fails to take corrective actions for the damaged /affected systems and shall deduct necessary amount from contractor's bills for such rectification jobs.

35 FORCE MAJEURE: -

In the event of either party being rendered unable by Force Majeure to perform any obligation as required under this contract, the relative obligation of the party affected by such force majeure shall, after notice under this article be suspended for the period during which such cause lasts. The term "Force Majeure" as employed herein shall mean acts of God, wars (declared or undeclared), riots or civil commotion, fires, floods and notices, acts and regulations of the Government of India or State Government of any of statutory agencies. Upon the occurrences of such cause and upon its termination, the party alleging that it has been rendered unable as aforesaid, thereby shall notify the other party in writing immediately but not later than twenty-four (24) hours of the alleged beginning and ending thereof giving full particulars and satisfactory evidence in support of its claim. During the period, the obligations of the parties are suspended by force majeure, the Agency shall not be entitled to payment at any rate. In the event of force majeure conditions continuing or reasonably expected to continue for a period more than fifteen (15) days, GNGPL shall have the option of terminating the contract agreement by giving seven (7) days' notice thereof to the Agency. If this agreement is so terminated, both parties shall pay to the other party, the amount payable up to the date of occurrence of such force majeure.

36 RESOLUTION OF DISPUTES/ARBITRATION:-

GNGPL has framed the Conciliation Rules 2010 in conformity with supplementary to Part – III of the Indian Arbitration and Conciliation Act 1996 for speedier, cost effective and amicable settlement of disputes through conciliation. Unless otherwise specified, the matters where decision of the Engineer-in-Charge is deemed to be final and binding as provided in the Agreement and the issues/disputes which cannot be mutually resolved within a reasonable time, all disputes shall be settled in accordance with Conciliation Rules, 2010.

Any dispute(s)/difference(s)/issue(s) of any kind whatsoever between/amongst the Parties arising under/out of/ in connection with this contract shall be settled in accordance with the afore said rules.

In case of any dispute(s)/difference(s)/issues(s), a Party shall notify the other Party (ies) in writing about such a dispute(s) / difference(s) /issue(s) between / amongst the Parties and that such a Party wishes to refer the dispute(s)/difference(s)/issues(s) to Conciliation. Such Invitation for Conciliation shall contain sufficient information as to the dispute(s)/difference(s)/issue(s) to enable the other Party (ies) to be fully informed as to the nature of the dispute(s)/difference(s)/issue(s), the amount of monetary claim, if any, and apparent cause(s) of action.

Conciliation proceedings commence when the other Party (ies) accept(s) the invitation to conciliate and confirmed in writing. If the order Party (ies) reject(s) the invitation, there will be no conciliation proceedings.

If the Party initiating conciliation does not receive a reply within thirty days from the date on which he/she send the invitation, or within such other period of time as specified in the invitation, he/she may elect to treat this as a rejection of the invitation to conciliate. If he/she so elects, he/she shall inform the other Party (ies) accordingly.

Where Invitation for Conciliation has been furnished, the Parties shall attempt to settle such dispute(s) amicably under Part-III of the Indian Arbitration and Conciliation Act, 1996 and GNGPL Conciliation Rules, 2010. It would be only after exhausting the option of Conciliation as an Alternate Dispute Resolution Mechanism that the Parties hereto shall go for

Arbitration. For the purpose of this clause, the option of 'Conciliation' shall be deemed to have been exhausted, even in case of rejection of 'Conciliation' by any of the Parties.

The cost of Conciliation proceedings including but not limited to fees for Conciliator(s), Airfare, Local Transport, Accommodation, cost towards conference facility etc. shall be borne by the Parties equally.

The Parties shall freeze claim(s) of interest, if any, and shall not claim the same during the pendency of Conciliation proceedings. The Settlement Agreement, as and when reached/agreed upon, shall be signed between the Parties and Conciliation proceedings shall stand terminated on the date of the Settlement Agreement.

Unless otherwise specified, the matters where decision of the Engineer-in-Charge is deemed to be final and binding as provided in the Agreement and the issues/disputes which cannot be mutually resolved within a reasonable time, all disputes shall be referred to arbitration by Sole Arbitrator.

The Employer [GNGPL] shall suggest a panel of three independent and distinguished persons to the bidder/Agency/supplier/buyer (as the case may be) to select any one among them to act as the Sole Arbitrator.

In the event of failure of the other parties to select the Sole Arbitrator within 30 days from the receipt of the communication suggesting the panel of arbitrators, the right of selection of the sole arbitrator by the other party shall stand forfeited and the EMPLOYER (GNGPL) shall have discretion to proceed with the appointment of the Sole Arbitrator. The decision of Employer on the appointment of the sole arbitrator shall final and binding on the parties.

The award of sole arbitrator shall be final and binding on the parties and unless directed/awarded otherwise by the sole arbitrator, the cost of arbitration proceedings shall be shared equally by the parties. The Arbitration proceedings shall be in English language and venue shall be Goa.

Subject to the above, the provisions of (India) Arbitration & Conciliation ACT 1996 and the Rules framed there under shall be applicable. All matter relating to this contract is subject to the exclusive jurisdiction of the court situated in the state of Delhi.

Bidders/suppliers/Agency's may please note that the Arbitration & Conciliation Act 1996 was enacted by the Indian Parliament and is based on United Nations Commission on International Trade Law (UNCITRAL mode law), which were prepared after extensive consultation with Arbitral Institutions and Centres of International Commercial Arbitration. The United Nations General Assembly vide resolution 31/98 adopted the UNCITRAL Arbitration rules on 15 December 1976.

PART – II of SCC

Scope of work

The Scope of Work for the Agency/Contractor shall include but not limited to the items mentioned below. The Agency/Contractor shall ensure proper upkeep and operational readiness of the CGD installations in normal working state at all times. Also, the contractor has to provide basic arrangements on agreeable terms that may be required in situations of emergencies.

Key essence for Safe Operation: The key essence of safe CGD Operations is to protect against any third-Party damages and maintain the network in safe manner. It is possible by Timely Gathering Information about any Third-Party Activity_in the vicinity of Gas Pipeline and making them familiar with the Gas Pipeline Network. The Contractor has to equip with all the possible ways/tools/methods in gathering such information and act on the same immediately to avoid any exigency. One of the Prime responsibilities of the Contract is to have robust Patrolling and developing effective liasioning with various stakeholders in collecting information about Third Party Activities in the vicinity of Gas Pipeline. Frequent Failure in collecting such information and consequent damages to PNG Network has potential to damage image of the GNGPL, which needs to be taken care seriously.

The contract for Operations & Maintenance of CGD Network in Geographical area of North-Goa and Ponda shall be Annual Rate Contract (ARC) for period of 1 years which can be extended to 1 more year on mutual consent at same rates, terms & condition.

To attend the MDPE pipeline damages by repairing in the minimum possible time. The contractor has to mobilize to the site immediately and restoration / repair should start within 30 minutes from the receipt of information regarding the emergency. The contractor should deploy suitable manpower (civil & fitter etc.) capable of attending the job professionally. Delay in mobilization and start of repair jobs shall attract penalty. The manpower deployed for Operations team shall not be disturbed for attending the emergency works.

1. The MDPE pipes of all sizes, Meters & Service regulators shall be free issue Material to the contractor and the contractor shall maintain records of these materials and reconcile periodically. All the above material shall be issued at GNGPL store and transport to O&M office or site shall be responsibility of the contractor. All material such as Fittings, valves, saddles fusion machine, generator etc required for repair and maintenance of MDPE network shall be procured by contractor. A minimum inventory for consumable needs to be maintained during the course of contract. However, the unused quantities of MDPE fittings shall be taken by GNGPL at invoice price at the time of closure of contract. All material shall be procured from the approved make by GNGPL. List of approved makes is attached elsewhere. (Minimum inventory required –List)
2. Supervisor deployed at O&M office shall monitor the contract & correspond with GNGPL. He shall be available round the clock with mobile phone and data connection. At no point of time the communication with the supervisor should break. He shall be responsible for coordinating all the jobs under this contract and for mobilizing the man and machinery at

site as per the requirement. During attending emergency, he shall be continuously monitoring the restoration jobs and correspond with GNGPL officer/s. He shall also monitor the O&M office day to day operations and data management operations. The supervisor and his team should be well provided with smart phones so that proper information can be shared among GNGPL and site. The supervisor shall also coordinate Pipeline patrolling & collection of Gas Meter reading, compiling and record keeping of the same on daily basis.

- 3. Any exigencies and consequents due to delay in attending the gas leaks and closing the isolation valves shall be borne by the Contractor and any legal issues/compensations due to negligence of the contractor team shall be borne by the Contractor without any liability to GNGPL. It is the responsibility of the contractor to maintain better Liaison with local authority, public & police to deal with any such exigencies.**
4. The wages for all the employees deployed by the Contractor shall be paid as per the relevant Labour laws & minimum wages applicable as per the circulars of Central Govt./state Govt. whichever is higher during the tenure of the contract. Any revision in minimum wages shall be taken into account while quoting. Any revision in the wages shall be adhered and no extra payment shall be payable during entire contract period of 1 years.
5. Various maintenance activities shall be communicated to the supervisor time to time by GNGPL and these shall be completed in stipulated time as per the specifications and standards provide by GNGPL.

6. Other jobs/activities in the Scope of the Contractor

The work force deployed by the contractor shall follow safe/standard operating procedure (SOP) along with the instructions/recommendation as given by GNGPL from time to time and strictly followed to ensure safety.

Proper PPE like safety helmet, hand gloves, safety goggles etc. shall be used during operation as well as during any maintenance activity.

All personnel of the contractor deployed for O&M office including supervisor shall be given 02 set of uniform for every six months, which shall be finalized in consultation with GNGPL. At any point of time NO O&M MANPOWER SHALL ENTER IN PREMISE OF CUSTOMER WITHOUT WEARING APPROVED UNIFORM. No deviation in this regard shall be accepted by GNGPL. An identity card shall also be issued to all person working for GNGPL in O&M office.

The manpower expelled from any contractor worked or working with GNGPL OR ANY OTHER CGD Company should not be recruited by any contractor. An undertaking of this

shall be given by contractor. The police verification by local police needs to be submitted by CONTRACTOR to GNGPL for all the persons deployed for O&M office.

In case the Contractor fails to submit and/or pay full detail of Manpower employed and the contributions payable, the Company shall recover from the monthly Bills of the Contractor the amount of the shortfall in contribution assessed by the concerned authorities. The amount so recovered shall be paid to the concerned authorities against the actual contribution payable for Employees State Insurance, Employees Provident Fund, etc.

Similarly, if contractor fails in paying salaries to manpower deployed for O&M office in a reasonable time then GNGPL have right to pay salaries to this manpower directly and deduct the amount after levying 15% overhead charges. The decision of GNGPL shall be final and binding to Contractor.

SCOPE OF WORK & SCHEDULE OF RATES DESCRIPTION

Note: At any point of time, payment for any job shall be done by single SOR item only for a specific job covered under the scope of that SOR and payment for other SOR items can't be claimed separately for completion of the Job. For example, for laying of pipeline in Open Cut, if JCB/Rock breaker are used for excavation, the item for laying of Pipeline through open cut shall include all such costs and no separate payment for hiring of JCB/Rock Breaker shall be made for completion of the Job. Wherever, the scope of work under any SOR includes excavation, the rate for such item shall include all the expenditures for completion of Excavation job and no additional payment shall be made.

1. **Hiring of Earth Moving Equipment (JCB):** This item of SOR shall be operated only when JCB is to be deployed as per the instructions of GNGPL Representative for executing specific Job. Whenever any other job listed in the other SOR items wherever, requirement of JCB is required for excavation, the rates for those specific SOR items shall include the cost towards deployment of JCB and no extra payment shall be made.
 - 1.1. Providing Earth Moving Equipment (JCB) with fuel, driver/operator, transportation with all tools, tackles and consumables required for excavation in all types of soil during MDPE/steel pipeline repair / restoration works, other maintenance jobs etc. within stipulated time frame of not more than one hour. Payment for deployment of Earth Moving Equipment (JCB) shall be done on hourly basis, however minimum four-hour payment will be made in case JCB is used for less than four hours.
 - 1.2. Operating time of Earth Moving Equipment (JCB) shall be considered from the time of deployment at site.
 - 1.3. Rates are inclusive of liaisoning with statutory authorities, other utility agencies and settlement of third-party claims for damages by Earth Moving Equipment (JCB).

2. **Hiring of Tractor Mounted RCC / Rock Breaker:**

This item of SOR shall be operated only when RCC/Rock Breaker is to be deployed as per the instructions of GNGPL Representative for executing specific Job. Whenever any other job listed in the other SOR items wherever, requirement of RCC/Rock Breaker is required for that job execution, the rates for those specific SOR items shall include the cost towards deployment of RCC/Rock Breaker and no extra payment shall be made.

 - 2.1. Providing Tractor Mounted RCC / Rock Breaker with Air Compressor / Pump fuel, driver/operator, transportation with all tools, tackles and consumables required for excavation in all types of soil during MDPE/steel pipeline repair works, other maintenance jobs etc. within stipulated time frame of not more than four hours. Payment for deployment of Tractor Mounted RCC / Rock Breaker shall be done on hourly basis, however minimum four-hour payment will be made in case RCC / Rock Breaker is used for less than four hours.
 - 2.2. Operating time of Tractor Mounted RCC / Rock Breaker shall be considered from the time of deployment at site.

2.3. Rates are inclusive of liaisoning with statutory authorities, other utility agencies and settlement of third-party claims for damages by RCC / Rock Breaker.

3. **Hiring of Tractor Mounted Air Compressor:**

This item of SOR shall be operated only when Air Compressor is to be deployed as per the instructions of GNGPL Representative for executing specific Job. Whenever any other job listed in the other SOR items wherever, requirement of Air Compressor is required for that job execution, the rates for those specific SOR items shall include the cost towards deployment of Air Compressor and no extra payment shall be made.

3.1. Providing Tractor Mounted Air Compressor with fuel, driver/operator, transportation with all tools, tackles and consumables required for flushing and de choking of MDPE pipelines and other maintenance jobs etc. within stipulated time frame of not more than four hours. Payment for deployment of Tractor Mounted Air Compressor shall be done on hourly basis, however minimum four-hour payment will be made in case Tractor Mounted Air Compressor is used for less than four hours.

3.2. Operating time of Tractor Mounted Air Compressor shall be considered from the time of deployment at site.

3.3. GI Pipe, Isolation Valves, Pressure gauge and other material required for connecting Air Compressor outlet to transition Fitting of MDPE Pipeline shall be in the scope of the contractor. No additional payment shall be made for the same.

4. **Hiring of Generator Set:**

4.1. Providing Tractor Mounted Generator Set (Diesel / Petrol) of 415V,50 Hz, 30KVA rating with acoustic enclosure along with driver/operator, transportation with all tools, tackles, fuel and consumables required for attending MDPE/steel pipeline damage repairing, other maintenance jobs etc. within stipulated time frame of not more than 8 hours. Payment for deployment of Tractor Mounted Generator Set shall be done on daily basis, however minimum half day payment shall be made in case of deployment of generator set as per instructions of EIC.

4.2. Operating time of Generator Set shall be considered from the time of deployment at site.

5. **Repairing MDPE pipeline damages (without excavation, backfilling & restoration):**

This item of SOR shall be operated whenever MDPE pipeline of all sizes is damaged by Third Party while laying their utility and all the support for restoration viz. making arrangement for JCB, Excavation for major portion, backfilling etc. are extended by the Third Party at site. Quoted rates shall include the cost for all material, manpower, equipment's, machineries and consumables for completion of the Job.

5.1 Operation and Maintenance team with required manpower shall reach the pipeline damage location within defined Turn Around Time (TAT) period of 30 minutes (or) at the earliest after receiving leakage complaint.

5.1. Scope includes providing required manpower, machinery and fittings etc complete.

- 5.2. Transportation including loading, unloading, handling of MDPE Pipes, Fittings, Diesel Generator, De-Watering Pump, Electro-Fusion Machine, MDPE Squeezers (both manual and hydraulic) etc. Tools and Tackles and other equipment as mentioned in elsewhere in the tender in the scope of the contractor and are readily available for attending emergency leakages from existing MDPE charged network.
- 5.3. Execution for working space and alignment for fusion joint etc including, dewatering (if required), Jointing, testing the network after repair, purging (wherever required), commissioning and backfilling, compaction, submission of testing and commissioning report is in the scope of the contractor.
- 5.4. Quoted rates are inclusive of liaisoning with statutory authorities, other utility agencies and settlement of Third-party claims if required.
- 5.5. **Penalty:** If the gas supply has not been restored within 8hr, penalty of Rs 1000/hr delay.

6. Repairing MDPE pipeline damages (with excavation, backfilling & restoration):

This SOR item shall be operated whenever MDPE pipeline is damaged by Third Party while laying their utility and the excavation of trench, Backfilling & Restoration shall be done by GNGPL. The quoted rates shall include manpower, equipment, fittings and all other Consumables required for completion of the Job.

- 6.1. Operation and Maintenance team with required manpower shall reach the pipeline damage location within defined Turn Around Time (TAT) period of 30 minutes (or) at the earliest after receiving leakage complaint.
- 6.2. Scope includes providing required manpower, machinery and fittings etc complete.
- 6.3. Transportation including loading, unloading, handling of MDPE Pipes, Fittings, Diesel Generator, De-Watering Pump, Electro-Fusion Machine, MDPE Squeezers (both manual and hydraulic) etc. Tools and Tackles and other equipment as mentioned in Annexure -1 is in the scope of the contractor and are readily available for attending emergency leakages from existing MDPE charged network.
- 6.4. Execution of the work including excavation of the pits, dewatering (if required), Jointing, testing the network after repair, purging (wherever required), commissioning and backfilling, compaction, submission of testing and commissioning report is in the scope of the contractor.
- 6.5. Quoted rates are inclusive of liaisoning with statutory authorities, other utility agencies and settlement of Third-party claims if required.
- 6.6. **Penalty:** If the gas supply has not been restored within 8hr, penalty of Rs 1000/hr delay.

7. Laying of MDPE Pipelines in all type of soil. - Open Cut /Moling Method:

- 7.1. Contractor shall carryout receiving, handling, loading, transportation and unloading of GNGPL supplied MDPE pipes which is free issue materials from GNGPL designated stock yards to Site/ Contractor's Own yards/ Work Sites.
- 7.2. Contractor shall carryout proper storing, stacking, identification, providing security and insurance cover for free issue materials.

- 7.3. Contractor shall carryout liasioning with landowning agencies / statutory authorities, preparation of detailed route plan, making trial pits (excavated to depth of 1.5 m or more as per instructions Engineer In-Charge) to determine the underground utilities/ services etc., obtaining permission from Land owning agencies, restoration of the abandoned excavation / trial pits to original condition, barricading the work area as per the procedures & drawings. and as per the directions of Engineer In-Charge/ Site In-Charge. The work under this SOR item shall include joining the new Pipeline laid with Existing Pipeline System.
- 7.4. **Open Cut Method:** Contractor shall carryout excavation of the trench to the required depth (normally 1m depth required from top of the pipe), uncoiling / stringing of pipes, lowering the MDPE pipe line in trench damping, jointing of the pipe ends/ fittings/ valves using approved electro fusion techniques as per specification by qualified personnel, padding around pipeline with suitable soil, supply and placement of PE warning mat over the pipeline along the complete route, flushing, testing, purging, commissioning, backfilling with available excavated material, compaction by putting water at subsequent layers of 150 mm, placement of all tiles/ slabs/ curb stones etc. removed during excavation.
- 7.5. **Moling Method:** Contractor shall carryout Survey of the existing underground utilities, submission of moling profile for approval as per attached technical specifications, excavation of entry and exit pits of required length, width and depth for launching of impact moling tool with launch cradle and receiving of impact moling tool, uncoiling / stringing of pipes, pulling of MDPE pipe line through the bore made by impact moling, damping, jointing of the pipe ends/ fittings/ valves using approved electro fusion techniques as per specification by qualified personnel, flushing, testing, purging, commissioning , backfilling with available excavated material, compaction of pits by watering at subsequent layers of 150 mm, placement of all tiles/ slabs/ curb stones etc. removed during excavation.
- 7.6. Contractor shall carryout restoration of excavated asphalted roads, PCC / RCC pavements, footpaths etc.as the case may be and shall be made motorable wherever pipelines are laid. **Payment for restoration shall be made separately as per SOR item 10.**
- 7.7. Contractor shall submit as built drawings, graphs, reports etc. as defined in bid document and as instructed by Engineer In-Charge / Site In-Charge. Rates are inclusive of liasioning with landowning agencies, statutory authorities, other utility agencies and settlement of third-party claims for damages while laying of MDPE pipeline by Open cut / Moling method.
8. **Laying of MDPE Pipelines in all type of soil – Horizontal Directional Drilling (HDD)Method without Casing:**
- 8.1. Contractor shall carryout receiving, handling, loading, transportation and unloading of GNGPL supplied MDPE pipes which is free issue materials from GNGPL designated stock yards to Site/ Contractor's Own yards/ Work Sites.
- 8.2. Contractor shall carryout proper storing, stacking, identification, providing security and insurance cover for free issue materials.

- 8.3. Contractor shall carryout liasioning with landowning agencies / statutory authorities, preparation of detailed route plan, making trial pits as per instructions Engineer In-Charge to determine the underground utilities/ services etc., obtaining permission from Land owning agencies, restoration of the excavated trial pits to original condition, barricading the work area as per the procedures and drawings and as per the directions of Engineer In-Charge / Site In-Charge.
- 8.4. Contractor shall carryout Survey of the existing underground utilities, submission of HDD profile for MDPE pipeline for approval as per attached technical specifications, excavation of entry and exit pits of required length, width and depth for launching and receiving of HDD pilot, uncoiling / stringing of pipes, pulling of MDPE pipe through the bore made by HDD Pilot, damping, jointing of the pipe / fittings/ valves using approved electro fusion techniques as per specification by qualified personnel, padding around pipeline in the pit with suitable soil, supply and placement of PE warning mat over the pipeline in the pit, flushing, testing, purging, commissioning , backfilling with available excavated material, removal of excess soil, compaction with watering at subsequent layers of 150 mm, placement of all tiles/ slabs/ curb stones etc. removed during excavation.
- 8.5. Contractor shall carryout restoration of excavated asphalted roads, PCC / RCC pavements, footpaths etc. and shall be made motorable wherever pipelines are laid.
Payment for restoration shall be made separately as per SOR item 10.
- 8.6. Contractor shall submit as built drawings, graphs, reports etc. as defined in bid document and as instructed by Engineer In-Charge / Site In-Charge.
- 8.7. Rates are inclusive of liasioning with landowning agencies, statutory authorities, other utility agencies and settlement of third-party claims for damages while laying of MDPE pipeline by HDD method.
9. **Laying of MDPE Pipelines in all type of hard ground strata / sedimentary rock etc– HDD Method without Casing:** The scope of work shall be same as above SOR item at Sr.No.8 but in hard ground strata. The contractor shall take prior approval from GNGPL before execution of this item.
10. **Excavation in all type of soil in trenches/ pits, Restoration of the area**
- 10.1. Excavation in all type of soil by manual or Mechanical means required for pits of all sizes/ trenches for a width of D+500 mm on each side of pipe and exposing the pipeline from top up to 500mm below the bottom of Pipeline including the stacking of excavated earth, lead up to 50m, stacked earth to be leveled and neatly dressed as per instructions of Engineer In-Charge / Site In-Charge.
- 10.2. Contractor shall carryout liasioning with landowning agencies / statutory authorities, preparation of detailed route plan, making trial pits (excavated to depth of 1.5 m or more as per instructions Engineer In-Charge) to determine the underground utilities/ services etc., obtaining permission from Land owning agencies, barricading the work area.

- 10.3. Contractor shall take utmost care while carrying out excavation of soil above the pipeline which is carrying highly inflammable natural gas. Chiseling, Hammering, excavation with earth moving equipment etc. shall not be carried out on the pipeline surface in any case.
- 10.4. Contractor shall exercise care to see that the fresh soil recovered from trenching operation intended to be used for backfilling over the laid pipe in the trench is not mixed with loose debris or foreign matter.
- 10.5. Contractor shall be responsible for making all necessary arrangement to remove or pump out water from the trench or from wet area, if required during excavation and repairing jobs that are in progress, without any extra cost/liability to the GNGPL.
- 10.6. Backfilling excavated earth (excluding rock) in trenches in layers not exceeding 20cm in depth, consolidating each deposited layer by ramming and watering as per instructions of Engineer In-Charge / Site In-Charge.

Restoration of Road surface

- 10.7. Contractor shall carryout restoration of excavated asphalted roads, PCC / RCC pavements, footpaths etc. and shall be made motor able wherever excavation is carried out.
- 10.8. Contractor shall supply approved quality material, testing of materials by third party agencies (if required) as per technical specifications / CPWD / IRC Standards, submission of the restoration reports. NOC from local authorities (if required) will be as per direction of Engineer In-Charge / Site In-Charge. It includes cases, where excavation was carried out to repair the damaged section of pipelines where the trench settles despite earlier restoration.
- 10.9. **Restoration shall withstand at least Six months from date of completion, else the restoration shall be done again by the contractor without any additional cost.**
- 10.10. Rates are inclusive of liasioning with landowning agencies, statutory authorities, other utility agencies and settlement of third-party claims for damages while excavation and restoration jobs.

11. INSTALLATION OF SERVICE REGULATOR (SR) MODULE

- Location for Installation of service regulator shall be decided by EIC
- Contractor shall ensure that the Service Regulator module is installed and supported on a bed of firmly compacted as per the drawing provided in this document.
- The SR module shall be supplied with pre-tested and ready for installation by GNGPL and frame mounted with housing or canopy will be provided by contractor.
- Contractor shall carry out all the necessary excavation/breaking of surface (Tar/RCC) etc. For Installation of Service regulator module as per the foundation drawing /specification attached
- Installation of Service Regulator should be in such a position that Flow direction of Service Regulator and gas flow in pipeline is in the same direction while

- connecting upstream and downstream of PE network
- Contractor shall ensure that usage of 90-degree EF elbow, Coupler for hook-up of the Service Regulator for 63mm and above size pipeline
- Contractor shall apply Golden yellow colour on foundation of Service Regulator
- Contractor shall connect inlet and outlet of service regulator module by appropriate EF fitting with transition fitting of SR module
- Contractor shall carry out functional testing of service regulator and carry out leak test prior to commissioning of service regulator as per instruction of EIC.
- Contractor shall carry out leak test of all the joints of Service Regulator module with soap solution during commissioning as per the instruction of EIC

12. Shifting work of service regulator

- Location for Installation of service regulator shall be decided by EIC.
- Contractor shall ensure that the Service Regulator module is installed and supported on a bed of firmly compacted as per the drawing provided in this document.
- Contractor shall carry out all the necessary excavation/breaking of surface (Tar/RCC) etc.
- For Installation of Service regulator module as per the foundation drawing /specification attached
- Installation of Service Regulator should be in such a position that Flow direction of Service Regulator and gas flow in pipeline is in the same direction while connecting upstream and downstream of PE network
- Contractor shall ensure that usage of 90-degree EF elbow, Coupler for hook-up of the Service Regulator for 63mm and above size pipeline
- Contractor shall apply Golden yellow colour on foundation of Service Regulator
- Contractor shall connect inlet and outlet of service regulator module by appropriate EF fitting with transition fitting of SR module
- Contractor shall carry out functional testing of service regulator and carry out leak test prior to commissioning of service regulator as per instruction of EIC
- Contractor shall carry out leak test of all the joints of Service Regulator module with soap solution during commissioning as per the instruction of EIC

13. Fabrication & Erection of New Valve Chamber:

The size of Valve Chambers (MDPE) would be 1m X 1mX1.5m (L*B*D) or of lesser size. The tentative drawing of Valve Chamber is attached in Technical Specification.

- 13.1. Contractor shall carryout all civil works including supply of manpower, materials, excavation of pit, piping supports including all PCC, RCC and Brick works for valve pits, addition of water proofing agent, pedestals with insert plates as required, sealing of pipe at pits, providing heavy duty cover etc., finishing, clean up, dewatering (if required) and restoration as per drawings, technical specifications & instruction of Engineer In-Charge.
- 13.2. Contractor shall also carryout installation of MDPE valve (If required) in valve chamber with required squeezing of charged gas pipeline network, cutting, cleaning,

scrapping, electro-fusion jointing, testing and commissioning of gas pipeline network.

- 13.3. Rates are inclusive of liaisoning with landowning agencies, statutory authorities, other utilities and settlement of third-party claims for damages while excavation and restoration jobs.

14 Fabrication of Valve Chamber Cover (new) along with precast RCC frame:

- 14.1. Contractor shall supply heavy duty RCC valve chamber cover of existing chambers. The item includes removing existing damaged cover and placing new cover with tools and tackles and manpower etc complete. The drgs of the cover shall be provided as per the site requirement.
- 14.2. Rates are inclusive of liaisoning with landowning agencies, statutory authorities, other utilities and settlement of third-party claims for damages while excavation and restoration jobs.

15 Repair / Modification in Size of Valve Chambers:

- a. Contractor shall carryout all civil works including supply of manpower, materials, excavation of pit, Precast RCC Frame of required height, Brick Work, PCC levelling course for connecting PCC wall chamber to RCC Frame, addition of water proofing agent, pedestals with insert plates as required etc., finishing, clean up, dewatering (if required) and restoration as per drawings, technical specifications & instruction of Engineer In-Charge.
- b. Rates are inclusive of liaisoning with landowning agencies, statutory authorities, other utility agencies and settlement of third-party claims for damages while excavation and restoration jobs.

16 Supply, Fabrication and Installation of New Pipeline Markers:

- a. **Steel Pole Markers:** Fabrication and Installation of Steel Pole Markers as per drawings. Structural steel work welded in built up sections, trusses & framed work including cutting, hoisting, fixing in position and applying a priming coat of good quality steel primer complete in all respect. Painting and lettering of warning markers as per drawings in Konkani/Hindi and English both by using synthetic enamel paint of standard make like Asian paints etc including cost of material. Job shall be carried out as per drawings, technical specifications & instruction of Engineer In-Charge. Steel Pole Markers should be painted and lettered with minimum three or more coats of specified colour paint. The grouting of Marker shall be with 1:2:4 grade Cement concrete having pit size 45x45x60CM including excavation and removal of excess soil in all type of soil/surface.
- b. **RCC Markers:** Fabrication, Casting and Installation of RCC Markers in all type of soil as per drawings. RCC Markers shall be constructed by cement concrete of grade as per the technical specifications and drawings [1:2:4 (1 cement: 2 coarse sands: 4 graded stone aggregate 20 mm nominal size)] and applying a priming coat of good quality primer complete in all respect. Painting and engraved lettering of

RCC markers as per specifications and drawings by using synthetic enamel paint of standard make like Asian paints/Berger paints including cost of material. Job shall be carried out as per drawings, technical specifications & instruction of Engineer In-Charge. RCC Pipeline Markers should be painted and lettered with minimum three or more coats of specified colour paint. Marker shall be grouted in Cement concrete of 1:2:4 grade with pit size 30x30x45CM.

- c. Rates are inclusive of transportation, loading and unloading of pipeline markers, liasioning with landowning agencies, statutory authorities, other utility agencies and settlement of third-party claims for damages while excavation and restoration jobs.
- d. Plate Marker: Providing and fixing Plate marker of approved size and design to the houses/apartment etc where PNG is being supplied.

17 Repair & Reinstallation of Pipeline Markers:

Re-installation of Uprooted Markers-RCC, Pole, all types of Markers: Reinstallation of Route Markers / Pole Markers/plate marker as per the attached drawings, along the route / along boundary wall, lamp posts including all associated civil works such as excavation and construction in all types of soils, construction of pedestals and grouting with concrete, cleaning, restoration of area to original condition and performing all works as per drawings, specification and instruction of Engineer-in-Charge. Contractor will provide a list of installation or reinstallation of markers to control room in charge and get their approval before start of work. The rate also includes liasioning with statutory bodies etc.

18 Painting & Stenciling of Pipeline Markers:

Cleaning, supply and application of approved color and quality of primer and paint, stenciling as per instruction of Engineer-in-Charge. The rate also includes liasioning with statutory bodies etc. The scope is for all types of markers up to 10 Digits/ Characters on individual markers. Contractor will provide a list of stenciling of markers to control room in charge and get their approval before start of work. In case of exceeding 10 digits/ characters on individual markers, payment shall be done on multiples of this SOR. Stenciling on marker including cleaning of marker surface, painting background with yellow paint, GNGPL Logo, 03 telephone numbers each having 10 digits, matter writing in Hindi / English as per drawing, through use of stencil etc. The font size shall be tentatively of 2 to 2.5 inches for each digit. The size and font however may vary with time. The rate shall be per marker. All tools and tackles are in contractor's scope.

19 Supply & Installation, Testing & Commissioning of GI pipes:

The scope in SOR is to extend the GI service network of sizes ½" to 1" diameter from the Isolation valve on the existing riser / lateral to individual house till the Meter Installation including the Service Regulator. This job shall be executed as and when the customer is ready to take PNG supply for his house. However, the network including Riser & Lateral would be existing for most of the apartments.

- a. The scope of the contractor shall include supply, installation, Testing, Commissioning, Painting & restoration of the GI network. The supply of coated C- class GI pipes of approved make, bends, couplers, clamps & all other fittings shall be in the scope of contractor. The contractor shall be required to provide all equipment, fittings,

tools and materials necessary to execute the work in an efficient and effective manner. Amongst other things the contractor's scope shall be to provide ladders, scaffolding pipe, dies, tripods, vices, fittings and Teflon tape, drills for concrete and other masonry, drills for timber and laminated surfaces inside customer's property, bending tools, clamps, sleeves to facilitate the pipe passing through floors and walls, paint for pipe marking etc. The threading of GI pipe shall be NPT and conforming to ASME / ANSI B1. 20.1. Contractor has to supply different types / sizes of approved clamps (Mild Steel) for fixing GI pipes suiting to the site conditions and the same shall be painted before fixing, as per the painting specifications. Every fresh lot of the clamps, brackets, regulators boxes and other consumables shall be approved by the EIC prior to start of installation. All lateral pipe shall be clamped to the building at intervals not exceeding two meters. Maximum distance between clamps shall be 1.0-1.5m when pipe goes to the straight, if any tee or fittings lies in between the pipe then clamp shall be placed 150 mm far away from center line of fittings at every sides. However, the same may be changed as per site conditions/as directed by EIC. Minimum gap between pipe and wall shall be 25 mm. The joints / fittings of the GI installations shall be painted only after carrying out testing of the installation. Where pipe passes through a balcony floor, the floor surface shall be made slightly elevated around the service pipe or its surrounding sleeve to prevent the accumulation of water at that point. Where a short piece of sleeve is used around the gas pipe, the sleeve should be embedded in the concrete with a mix of mortar and the void between the pipe and sleeve filled with a suitable sealant. The sealant should be beveled such as to prevent an accumulation of water. Supply of clamps for all sizes of the GI pipes are in contractor's scope. Contractor has to take prior approval for design of clamps, paintings etc. Pipe shall preferably enter a building aboveground and remain in a ventilated location. The location for entry shall be such that it can be routed to the usage points by the shortest practicable route. The contractor shall ensure that gas supply shall not be provided to the customer in any concealed piping. The GI Network shall be tested as per the testing procedure. Payment for this item shall be made on Installation, testing, Purging & commissioning of the entire network successfully.

- b. The measurement for this SOR shall be Running Meter.

ONLINE TAPPING FROM RISER / HORIZONTAL COMMON HEADER GI PIPELINE

Following Guideline shall be followed during on line tapping from commissioned GI Riser or Horizontal Common header.

1. Hot Work permit shall be issued by GNGPL, O&M.
2. It shall be ensured that all required tools and tackles and consumables are available at site.
3. It shall be intimated to all affected customers prior to isolation of Riser supply and isolate their main isolation valve.
4. It shall be ensured to Closed / complete isolation of main control valve and

- proper tagging shall be done for closing.
5. Keep one person near Main isolation valve to ensure no one will operate the valve during on line tapping work.
 6. Proper PPE shall be used for on-line tapping.
 7. End plug from where tapping shall be done to be removed slowly until complete venting of Natural Gas from Riser pipeline.
 8. After complete venting of Natural Gas from Riser pipeline, check with soap solution to ensure no passing of Natural Gas from Main isolation valve.
 9. Ensure complete fitting of GI pipe up to individual main isolation valve. If further GI installation up to meter and appliance valve is not planned on same day then fix hollow hex plug. Ensure no leakage/valve passing before starting balance work of the connection.
 10. Open main isolation valve and carry out leak check with soap solution of newly fitted GI pipeline.
 11. After ensuring no leakage, open individual main isolation valve and ensure proper gas supply to the customers and ensure no open end is left before leaving the site.

TESTING OF GI INSTALLATION

Before carrying out the pneumatic test of the GI installation; testing assembly, air foot pump with pressure gauge / manometer shall be checked its calibration and proper functioning.

Before pneumatic testing of the installed connection spacing between two clamps, tightening of the clamps thread joints, alignments of the whole piping shall be checked. Valve shall be kept in open position and the appliance valve shall be kept in close position.

Ensure Meter and Regulator is not installed during PPT. Proper Meter spool piece shall be installed during PPT (No flexible hose to be allowed).

Ensure during the testing, air should reach up to the appliance valve. After completion of testing, pressurized air shall be released from appliance valve only.

Calibrated pressure gauge shall be used having the range up to 1.5 times of test pressure and least count of gauge should be 0.1 Kg/cm²

Position of the pointer of the pressure gauge shall not be marked with the marker pen on the glass. It should be recorded in the test recorded during Pneumatic testing of GI Installation.

After pressurization of the whole piping section shall be checked for the leakage with the help of soap solution.

The installation from PE / GI transition fitting up to regulator shall be tested at the pressure of 6 .0 Kg/Cm²) or at 150 mbar as the case may be.

The testing of GI riser pipe up to regulator shall be done with the isolation valve in open condition and open end plugged.

The GI installation from regulator outlet to appliance valve (except meter) shall be tested at a pressure of 1.5 times to working pressure for a hold period with no pressure drop. All the joints in the installation shall be checked with soap solution.

The contractor shall supply the Calibrated Pressure Gauges / Manometer / Diaphragm Gauges range for testing of GI Installations.

The contractor shall supply the Pressure Gauges, Manometer and Diaphragm Gauges range for testing of GI Installations ranging from 0-4 bars / 0-150 mbar / 0-250 mbar respectively.

The calibration certificate shall be submitted before the start of the execution work. The pressure gauges shall be calibrated from time-to-time as desired by EIC but positively once in every Six months.

The GI pipe shall be painted with one coat prior to installation in riser; however, the ends/joints shall be painted only after carrying out testing of the installation.

The details of testing shall be properly recorded in the GI cards.

PURGING & COMMISSIONING

The rate for purging & commissioning shall be included in the GI installations. Contractor shall ensure that the outlet is so located that vent gas cannot drift into buildings. Contractor shall perform the commissioning of the GI installation as follows:

1. Ensure the method of purging is such that no pockets of air are left in any part of the Customer's piping.
2. Ensure that all appliance connections are gas tight, all appliance gas valves are turned off and there are no open ends.
3. Where possible, select an appliance with an open burner to commence the purge i.e., a hotplate burner.
4. Ensure the area is well ventilated, and free from ignition sources.
5. Ensure branches that do not have any appliance connected are fitted with a plug or cap.
6. Turn on one burner control valve until the presence of gas is detected. A change in the audible tone and smell is a good indication that gas is at the burner. Let the gas flow for a few seconds longer, then turn off and allow sufficient time for any accumulated gas to disperse.
7. Turn on one gas control valve again and keep a continuous flame at the burner until the gas is a light and the flame is stable.

20. Providing Domestic PNG connection:

Domestic PNG connection shall be provided in this item which include fixing meter with or without regulator, providing and fixing copper piping, providing and fixing appliance and isolation valve if required as per SOR.

21. Re-install GI pipe using old pipe:

Removal & Re-Installation of GI Pipes using old removed pipes. If quantity of reinstalled pipe is more than removed Pipeline, then charges for additional pipe length shall be applicable as per separate SOR. To maintain minimum inventory of material, consumables as per instructions of GNGPL In-Charge. Prior assessment of shortage & material requirement for installation at site, order placement for Purchasing of GI Pipes & GI Fittings, Copper pipes & Copper fittings, Brass Fittings from GNGPL's approved vendors (list attached in tender),). However, inspection certificate issued by TPIA shall be submitted along with MRV when asked by GNGPL. Receiving, taking over, handling, loading, transportation and unloading of GNGPL supplied above ground items like regulators, meters, GNGPL's designated stock yards to Contractor's own stores / work sites, proper storing, stacking, identification, providing security insurance cover. Making temporary but stable platforms/ scaffolding/ rope ladders and supply of all other safety devices including full body harness of PETZL or equivalent make.

Installation of GI/ Copper service pipes & fittings only for modifications & extra points, replacement of Meter, regulators, Valves etc. including NPT threading, as specified, Drillings of holes through the walls (Brick, RCC), Granite, Marble, Wood Cutting, Glass Cutting with proper heavy duty hammer drill machine, tools & tackles, using proper sealant/grout material and colors to match the original replacement of the damages during drilling, restoring the area to the original condition, Painting of entire length of pipe along with fittings after proper surface finish by one coat of approved primer paint and two coats of approved synthetic enamel paint. Restoring the wall surface to original conditions, Supply & fixing of approved clamps & dowel Plugs with screws, grout material, suitable thread sealant i.e., Teflon Tape / lock tight, joining of transition fittings to above ground service. GI pipes testing, purging and commission of the complete installation. Planning & coordination with existing consumers for testing of existing risers and re-commissioning of existing connections. All installation/re-installation carried out with GI/Copper will be paid on running meter basis. These rates include testing and commissioning. This SOR shall be applicable only in case of emergency and leakage complaints. GI, Copper, brass fittings shall not be counted separately. It shall be included in the measurement of GI & Copper pipe. Dismantling of GI Pipes and Copper Pipes shall also be included while executing the SOR.

22. Calibration of All Gauges & SRV to be maintained by the contractor (DRS/MRS/ODOURIZING UNIT/CNG COMPRESSOR/ S CASCADE/ M CASCADE)

Contractor has to maintain the record of calibration date of every gauge (PG, TG etc.) installed in the DRS/MRS/CGS/CNG Cascades etc. Contractor shall carryout the calibration of all the gauges before the due date in advance. Calibration shall only be carried out from NABL approved laboratories and provide valid certificate to that effect. The job includes record keeping, identification, removal, transportation to lab and back, installing back of gauges.

23 MDPE Valve & Valve Chamber Operation, Maintenance & House Keeping:

Scope includes opening of valve chamber, operate the valve with / without wheel and lubricated if required as per SWP issued by GNGPL once in three months. The valve Chamber need to be kept clean always and remove any grass, debris, Water inside the valve chamber and paint the Valve chamber with Details of Tag No and other details. All the consumables are in the scope of contractor.

24 Maintenance & House Keeping of DRS& MRS:

The maintenance of District Regulating Stations shall be carried out monthly. During maintenance, filter cleaning all the valves shall be operated, sealed and lubricated as per SWP issued by GNGPL. Changeover of the operating streams shall be done monthly / as & when required. During change over, before change over existing stream parameters shall be recorded in the formats provided and the changeover shall be executed as per the SOP provided by GNGPL. Cleaning shall be done. All the consumables, Manpower etc shall be in the scope of Contractor.

Work Instructions for Cleaning / Replacement of Filter Elements of DRS /MRS

- Ensure that filter body is de-pressurized by opening drains and top gauge

connection. Venting is done under controlled condition with all safety precautionary measures as per work permit system.

- Before starting venting operation, ensure that DRS inlet and outlet valves are closed.
- Unbolt bolts of Top cover of filter & Remove Filter top cover, carefully.
- Remove filter element carefully, after removing the nut on element guide rod.
- Observe / check the inside of filter body and element fixtures for any abnormality, and finally clean inside of the filter body.
- Clean the faces of filter cover and body
- Similarly clean and reuse the old element, if possible.
- If required, replace the element with new element.
- Refit the element by screwing down the nut, washer and rubber packing, on guide rod.
- Use the old gasket if the condition of the same is good. If not replace the same, by new gasket.
- Refit the top cover by bolting down equally on all sides.
- Carry out the leak check of cover joint by soap solution, when the filter is pressurized after completion of all other jobs on DRS.
- Prepare the report and update the record including, spares / material consumption statement and submit to GNGPL in charge for material reconciliation and inventory management.

Work Instruction for Routine Maintenance of DRS / MRS

- Check CH₄ % with gas detector and carry out leak test with soap solution, of all pipe, valve and tube joints
- Clean externally all valves, drains vents, pressure gauges, pipe spools and pilot regulators and filter, with dry clean cloth
- Operate all valves in clock-wise/anti clock-wise direction frequently to make all them free in operation
- If found necessary paint all valves and other valves with blue colour, pipe, vent pipe with yellow colour, Filter with silver colour , S.R.V. with red colour , P.R.V. & S.S.V. with sky blue colour. (Work to be executed only on receipt of WO)
- If Regulator No. / Equipment No. is not visible, required marking is done with appropriate paint.
- Close the cabin and fencing gate and lock it.

25 Dismantling of GI Pipe all Sizes:

Dismantling/removal of GI service pipes & fittings on customer/ end user request and store at contractor's store. After completion of contract, return back balance dismantled material to GNGPLs Control room. This includes restoration of holes left out after removal at customer's premises. Contractor shall submit material details & meter reading data to control room immediately after dismantling or as directed by control room in charge. This SOR shall be applicable only in case of emergency and leakage complaints. GI, brass fittings shall not be counted separately. GI pipes and fittings

dismantled shall be returned back to GNGPL Control room.

26 Conversion of Domestic customer:

Conversion to start the supply to customer with changing the LPG stove nozzels of all make. The jobs need to be done by skill person with all tools and tackles. The surksha hose needs to be changed as per requirement. If surksha hose is required to be changed than payment of same shall be paid through separate item in SOR. The item includes filling the conversion form and taking signature of the customer after taking initial reading of the meter etc. The rate quoted by the party shall be applicable for north Goa and Ponda and shall be inclusive of all material, manpower as well as transportation etc complete

27 Re-Install Copper Pipe Using Old Pipe: Installation of Copper pipes & fittings only for modifications & extra points, replacement of Meter, regulators, Valves etc. threading, as specified, Drillings of holes through the walls (Brick, RCC), Granite, Marble, Wood Cutting, Glass Cutting with proper heavy duty hammer drill machine, tools & tackles, using proper sealant/grout material and colours to match the original replacement of the damages during drilling, restoring the area to the original condition. Restoring the wall surface to original conditions, Supply & fixing of approved clamps & dowel Plugs with screws, grout material, suitable thread sealant i.e., Teflon Tape / lock tight. Cu pipes testing, purging and commission of the complete installation. All installation/re-installation carried out with copper will be paid on running meter basis. These rates include testing and commissioning. This SOR shall be applicable only in case of emergency and leakage complaints.

28 Dismantling of Copper PIPE: Dismantling/removal of CU & Copper service pipes & fittings on customer/ end user request and store at contractor's store. After completion of contract, return back balance dismantled material to GNGPLs Control room. This includes restoration of holes left out after removal at customer's premises. Contractor shall submit material details & meter reading data to control room immediately after dismantling or as directed by control room in charge. This SOR shall be applicable only in case of emergency and leakage complaints. Copper, brass fittings shall not be counted separately. Copper pipes and fittings dismantled shall be returned back to GNGPL Control room.

29 Painting – GI Pipes All Sizes (up to 1”): Painting - GI pipes, painting of above ground at all heights of GI pipe along with fittings of various sizes installed at domestic and commercial connection after proper surface finish by one coat of approved primer paint and two coats of approved synthetic enamel paint complete as per specifications & directions of EIC. Restoring the wall surface to original by cleaning / touching of the corresponding paint to original as per instructions & to the satisfaction of the EIC.

30 Supply & providing of GI sleeves with pedestal: Supply & installation of GI Sleeves, 2.5" NB x 300 mm length GI Sleeve for domestic connections, 3" NB x 300 mm length GI Sleeve for commercial and industrial installations, excavation, breaking through any

obstructions, Squeezing of MDPE pipe near to Transition fittings, dismantle of regulator, shutdown the riser /individual connections, insertion of GI pipe, sealing the annulus, firm fixing of the sleeves with concrete mix, preparation of pedestal & restoration of excavated pits within the size of pedestal as per instruction of EIC. The rate includes liaisoning with statutory bodies if required and no separate rates are payable.

31 Supply of Suraksha hose confirming to IS 9573 Type-2 with clamps and nozzles - For conversion from LPG to PNG: The scope includes Supply of Suraksha hose with clamps and nozzles for conversion from LPG to PNG. Contractor has to maintain sufficient quantity at all times so that conversion jobs & gas leakage issues are not affected.

32 Supply of Un-Skilled Manpower: The scope includes supply of unskilled manpower for any particular job not covered in the SOR anywhere for meeting any special exigencies as per the instruction of EIC/GNGPL Representative.

33 Pipeline Patrolling:

The Pipeline Network in CGD is vulnerable and susceptible for damage due to excavation by Third Party Agencies. The key & prime essence for safe operations of the MDPE network is to protect the steel & MDPE network from any third-party activities. This can be achieved only by gathering early information of any such activities in the vicinity of the Gas pipeline. The prime responsibility of the Contractor is to gather/collect such information by all means and communicate to respective O&M office immediately for corrective action. One of the ways in gathering such information is by doing Patrolling thoroughly. Failing to gather any such information about third party activity may lead to gas leakages and consequent damages there off. Patrolling activity shall be the “Eye & Ear” of O&M team to protect the pipeline network. **Slackness/Negligence in Patrolling activity shall be viewed seriously and frequent failures of Steel & MDPE damages due to lack of knowledge & intimation to O&M office may lead to termination of the Contract.** For effective Patrolling of MDPE network the key activities listed below (but not limited to) shall be performed by the Contractor under this scope of Work.

- a. Each Patroller shall be designated certain portion of area to be patrolled during the shift along with Pipeline route map. Each designated Patroller with designated portion of area shall cover minimum 2000 km of Pipeline per month i.e., average 65 km per day.
- b. Patrolling activity shall be carried out on two-wheeler fitted with GPS based vehicle tracking system. The speed limit of the Two-wheeler shall not cross 20 km/hr. Patroller shall always take path of the Pipelines as per the route Map. Any deviations from the pipeline shall not be considered for measurement of Patrolled length.
- c. Contractor has to arrange for live tracking of the movement of Patrolling vehicle and access to the GPS monitoring system shall be provided to GNGPL personnel for monitoring & review of effectiveness of patrolling. At no point of time the GPS tracking should fail and immediate action shall be taken for early restoration. During failure of the GPS tracking, the patroller shall submit the Google Map tracking system using his mobile while patrolling along with various pictures taken

with smart phone with location attribute switched 'ON'. This is only a contingency method and should not be adopted as regular practice. Maximum of one day break down of GPS is acceptable in one month and efforts shall be put to restore the system as early as possible.

- d. Designated Patroller should make himself well acquainted and make himself familiar with the Pipeline route, location of Valves, Markers etc. The Contractor along with Patrollers shall maintain liaison with various Third-Party Agencies, JCB associations, HDD Agencies, RWA, Local public/vendors so that any activity along the Gas pipeline is reported to GNGPL. Contractor shall adopt all possible endeavors to gather information about third Party activities along the gas pipelines.
- e. For effective patrolling, the contractor shall engage local teams & avoid frequent replacement of the Patrollers.
- f. The prime responsibility of any patroller shall be to inform any activity along the Gas pipeline to respective O&M office and the Supervisor/Shift In-Charge with Picture & location of the incident through Mobile.
- g. Patroller shall immediately stop any unauthorized digging activity near Gas pipeline & inform GNGPL respective base & Supervisor.
- h. Patroller shall carry Valve Keys along with him, rush to the site and shall close the nearest isolation valve in case of any eventuality and inform GNGPL. Supervisor shall rush to the site for taking stock of the activity and control.
- i. Contractor's scope shall be to deploy bikes, safety gadgets, Insurance and abide by all the Traffic rules & regulations. The charges for fuel, GPS Tracking system and all other consumables, tools shall be in the scope of the Contractor. The decision of EIC/ Site in Charge shall be final and binding for arriving the length of pipeline patrolled. For execution of patrolling the contractor shall maintain sufficient number of bikes.
- j. The patroller will start the patrolling in the designated route and carry out a thorough patrolling & checks like Road/Nallah/Rail Crossing, Valve-Chamber, CP station/Warning, Excavation on Pipeline, Gas Leakage if any, condition of Markers, MRS & DRS etc. should be done during patrolling.
- k. When the patrolling is finished by the patroller & arrive at the end point, supervisor should be present there to collect the patrolling format & review the observations those are written by the patroller. The Patrolling Track record shall be downloaded from the GPS system and validated with GNGPL representative at the end of each shift and kept for records.
- l. If there is no observation found in the format, the verbal discussion shall be done with the patroller to know about any third-party activities which are going along the pipe line route. If there is any observation is noticed during patrolling, the patroller/supervisor shall report the same to GNGPL engineer immediately from the site.
- m. In case of any observation is mentioned &/or narrated by the patroller, then the supervisor shall rush to the site of the vulnerable location to confirm the third-party activity. The vulnerable location shall be filled by the patroller/ supervisor & shall

be submitted to the O&M in-charge of the respective site. The format after site visit & review shall be submitted to GNGPL.

- n. The supervisor should monitor the time taken for the patrolling by the individual patroller. If the patroller takes more time for patrolling the particular section/ area of the pipe line which has been assigned to him, he may be enquired for the delay.
- o. In future if GNGPL develops any online monitoring of Patrolling activity through Geo-Fencing and Mobile App. Contractor shall adopt to such systems.

34 Providing Services for O&M office

For smooth Operation and Maintenance of PNG network upon network penetration, customer care service, minimum response time to control any exigencies GNGPL want to open an O&M office as per the requirement basis.

All the activities required to operate & maintain the PNG Network and attending to Customer complaints/ any leakage/ operation of valves and other requirements shall be covered in the scope of this SOR. The Major activities but not limited are as below:

- a. Services for O&M office shall be on 24 hr. basis in 3 shifts of 8 hr. each.
- b. The minimum workforce/manpower with requisite qualifications, to be deployed for the O&M office shall be as below:

S.N.	Description	Qty. (No)	Total per Day	Desired qualification
1	Supervisor (Highly Skilled) shall be responsible for Entire Operations. He shall be overall responsible for O&M activities.	1	1	Engineering graduation with Mech/Elect/Instrument having experience of 2-3 year in CGD business.
2	Technicians in each shift (Semi Skilled for PNG)	1	3	ITI with experience of 1-2years
3	Technicians in each shift (Semi Skilled for CNG/Steel Pipeline)	1	3	ITI with experience of 1-2years
4	Plumber in each shift (Semi Skilled)	1	3	Should have good skill in plumbing
5	Helper in each shift (Unskilled)	1	3	Should have knowledge in CGD
6	Receptionist cum Data Entry Operator (Semi-Skilled)	1	1	Should have good communication skill. Speaking knowledge of Konkani, Hindi & English is must. With MS Word, MS excel knowledge.

- c. Contractor shall deploy Minimum 03nos Two wheelers at O&M Office around the clock to attend day to day O&M activities. At any point of time the work should never get effected due to non-availability of vehicle. The fuel as well maintenance of these Three two wheelers shall be in scope of contractor.
- d. The Supervisor shall be responsible for entire activities of O&M office round the clock and co-ordinate with his team and Site manpower. The supervisor shall co-ordinate with Patrollers, shift teams and other personals required time to time &

GNGPL official for smooth and safe operations of CNG & PNG network. He shall be responsible for data management for all the activities for O&M. The sole moto of the O&M team shall be to ensure uninterrupted gas supply to consumers. **For this purpose, contractor has to deploy an experience person at O&M offices who has minimum 2-3 years' experience of O&M activities in CGD. The contractor shall provide necessary replacement whenever the deployed employee is proceeding on leave.**

GNGPL comes under the purview of Ministry of Petroleum and Natural Gas, Govt of India. Hence central labour minimum wages is applicable to GNGPL Bidder has to ensure that wages not below central govt. Minimum wages are paid to all deployed manpower.

- e. Data Management Services: Preparation of log of all the complaint received at O&M office and its resolution. Preparation of various reports on daily, weekly & monthly basis. Data analysis, Daily Gas Reconciliation, projection of gas consumption in line with the trend, updating various progress activities, preparation of daily pipeline patrolling data, monitoring of gas consumption of various consumers and reporting any abnormalities in consumption to GNGPL. Collection & collation of data related to billing as per billing cycle and attending billing related issues. Preparation of data for billing for domestic, commercial & industrial customers. Contractor shall provide Identity cards, Uniform, PPE to all the employees deployed by him under this contract. The identity card should be traceable with any of the Identity cards issued by Govt. of India. The persons deployed shall be qualified enough to attend the problems related to CGD customers and shall have working knowledge of Konkani/Hindi & English. The dress code for these technicians shall be provided by GNGPL. These technicians attending the customer complaints shall always be well behaved and shall never indulge in any type of activities due to which GNGPL reputation is jeopardized. If any technicians found guilty shall be immediately removed from the duties and replaced with suitable manpower.
- f. No charges shall be levied on the customers by the contract personnel for attending the complaints and any type of monetary in terms of cash shall be demanded by the contract personnel in this regard. If such cases were brought to the notice of the GNGPL employees, suitable action in terms of penalty shall be levied if found guilty. On repetition of such incidents, the contract shall be terminated and PBG shall be forfeited.
- g. The scope includes but not Ltd. to, attending to various calls from Customers regarding Gas complaints viz. no gas, gas leak from Copper tube, stove, Isolation valve, Union, low flame, Resetting the Service Regulator, conversion from LPG to PNG, risers testing, assistance during calibration of PSV's, updating gas composition in MRS etc., third party pipeline damages, continuous supervision of pipeline excavation jobs done by third party at GNGPL pipeline, interaction with

other agencies and attending to the calls received. All the tools & tackles, brazing equipment, etc. shall be arranged by Contractor.

- h. Utmost priority shall be given to the calls / complaints received from customer/ customer care. The team shall rush immediately to the effected location and best efforts shall be put for resolving the complaint.
- i. No Gas & Low Flame complaints shall be resolved within one-hour time. In no case, any type of lacuna in attending to the customer calls/ complaints is acceptable. If the compliant takes considerable time to attend, same shall be intimated to the customer and in no case domestic & commercial complaints related to Gas burners in Domestic & Commercial shall be left unattended beyond 6hrs from the receipt of compliant. Penalty clauses referred elsewhere in this SCC shall be applicable in case of non-compliance of any of these conditions. Decision of EIC shall be final & binding.
- j. Necessary SWP (Standard Work Procedure) shall be issued to contractor by GNGPL from time to time and the contractor shall strictly follow these procedures.

Meter reading Domestic customer: At GNGPL all domestic customers are connected with mechanical meters, readings of these Meters shall be taken manually in person by visiting each individual house. Meter reading needs to be taken as per the bill cycle for domestic customer by visiting the premise of the customer and taking photo of the meter through smart phone and loading in the system. In case, system is not working than take the physical reading along with photo of the meter and submit it to designated GNGPL official. The frequency for billing cycle shall be once in 2 months. However, reading can be taken on need basis also. For taking reading a separate person shall be deputed as per the requirement. It will be responsibilities of the Supervisor to submit all billing related data to concerned GNGPL.

- k. **Meter Reading- Commercial / Industrial Customer:** Gas consumption readings for all Commercial & Industrial customers need to be taken from the meters installed at various customer's premises on daily basis. The gas meter readings for the above all customers shall be taken daily between 06.00 am to 07.00 am. It will be responsibility of the shift in charge of morning shift to ensure reading are being taken. These readings shall be communicated to designated GNGPL officer by email by 8.00 am and by 'Whatsapp' mobile application by 08.00 am on daily basis. While taking the meter readings the following observations shall be made and communicated to GNGPL personnel regularly as per the format & parameters provided by GNGPL:

- a. Meter & its accessories condition.
- b. Battery backup / power supply condition
- c. Operating stream
- d. Gas Leakage
- e. Any other abnormal conditions

- l. **Assistance in Updating Gas Composition in the Meters:** Gas composition is to be updated in the metering skids / consoles installed at various commercial / Industrial customers on fortnightly / monthly basis as guided by GNGPL. The

measurement for this SOR shall be number of times the Gas composition is updated. Twin Stream Skids shall be considered as Single unit. Assistance in Calibration of PSV, Measuring Instruments viz. PG. TG etc.

- m. The quoted Rate for this SOR items shall include but not limited to the following and no additional charges shall be payable other than Quoted Rate:
- a. Monthly wages for the Manpower deployed as per Govt. Wage circular, ESI. Insurance etc.
 - b. Uniform & PPE, Identity Cards etc.
 - c. Deployment of 02 two Wheelers along with GPS tracking, fuel, maintenance charges.
 - d. Communication charges among employees
 - e. Consumables
 - f. All the stationary
 - g. Any other charges to execute this SOR as per the Scope.
- n. The office space for this O&M office at shall be kept clean and tidy on daily basis. The office space shall be swept and mopped twice daily without fail and further as and when required and disposal of the waste at designated location. further the contractor shall provide services for office attendant whose job shall be mainly but not limited to, photo copy of the documents, filling/arrangement of various documents, serving tea/ snacks, keeping the serving utensils clean. The consumables for housekeeping activities shall be in the scope of contractor. The person deployed for these services shall keep the office premises and self in good hygiene. The materials required for housekeeping shall be in the scope of contractor.
- o. **Penalty:** If manpower in a shift or general shift is less than the standard mentioned manning a penalty of Rs 2000/person/shift shall be applicable.

Conversion Of Appliance from LPG to PNG:

Conversion of Appliance from LPG to PNG - Hot Plate Burner/Grill/Burner (supply of Reinforced Rubber Hose with Clamps shall be covered in other SOR). The major jobs include but not limited to the following:

- a. Removing the existing flexible hose connections from the LPG cylinder to stove through LPG regulator. Connecting the existing LPG stove with New Flexible Hose (Suraksha Hose) of 1.0 m / 1.5 m with the outlet of Isolation valve and fasten the hose with hose clamps tightly.
- b. Modification/conversion of the existing LPG stove burner suitable for PNG by removing the existing Nozzles of sizes 85 μ & 55 μ with 125 μ & 110 μ nozzles and any other nozzle suitable for PNG. The scope of supply of the new nozzles shall be in the scope of the contractor. Changing of nozzles and associated controls as per the requirement for conversion of the burner in complete.
- c. Adjusting the hole / Sim of the jet for gas inlet suitable for PNG so that flame is not put-off during the knob operation in all the positions.

- d. Testing for gas escapes from meter, regulator & the soundness and performance of the appliance to the satisfaction of the customer. Cleaning and performing minor maintenance of appliances.
- e. Contractor must attend the complaints regarding appliances till the total area is handed over to GNGPL's operation and maintenance.
- f. All consumables (Nozzles, greases etc.) are in contractor's scope & changing or repairing of any items damaged during conversion.
- g. Filling up the gas connection commencement form supplied by GNGPL and get the signature of the customer after noting down the initial meter reading (Signing of Joint Meter Records (JMRs) and submit to GNGPL for record updating.
- h. Issuing Safety instructions to customer for use of PNG. Sticking the Emergency Contact number details provided by GNGPL on the Meter. All the tools & paraphernalia for the above job shall be arranged by the contractor

DIS-CONNECTION (DC) / RE-CONNECTION (RC)

DIS-CONNECTION

Disconnection procedure can be categorized into two following type, volunteered or forced disconnection.

VOLUNTARY DIS-CONNECTION

Billing officer/cashier shall receive the consumer application and request charges only if the consumer has no dues with GNGPL. If above condition is satisfied then the request charges as decided by GNGPL shall be taken and details of same shall be forwarded to GNGPL representative on daily basis.

technical group on successful disconnection shall intimate .In case the house is found locked, then Contractor shall submit of House locked status and reattempt will be made after few days or by taking suitable time from customer on phone.

FORCED DIS-CONNECTION

Forced disconnection shall be carried out in following cases:

Non-payment of gas consumption bill for more than two (2) billing cycle (i.e. more than 4 months), or as instructed by GNGPL.

Non-payment of installation cost, penalty, contract renewal charges for various reasons.

Using gas with unsafe installation / circumstances or tempering / manipulation of installation / equipment or for any other technical / non-technical reason.

Disconnection will be carried out with prior authorization / instruction of GNGPL.

After successfully carrying out such disconnection, necessary report submitted to GNGPL representative. The charges and modes shall be decided by the GNGPL. CONTRACTOR should ensure that no such consumer shall be reconnected without clearing the matter, collecting the outstanding amount along with the penalty and re-connection, charges, as per the policy. Forced disconnection shall be carried out as and when required or as instructed by GNGPL.

In Case of Forced Disconnection to be carried out in High rise buildings or Flats, Contractor has to arrange for PETZAL (Julha) to perform the activity. The Contractor can raise bill for same based on SOR of GNGPL.

RE-CONNECTION

On receipt of consumer request for re-connection, billing personnel should ensure that the disconnection was done volunteered or forcefully.

If disconnection was done forcefully, do not accept request or carry out re-connection without clearing the matter, collecting the outstanding amount along with the re-connection charges, penalty as per policy. Do not accept the payment in cheque for such cases. If consumer satisfies the clearance process, then forward the application to the GNGPL representative.

Technical group on successful reconnection shall intimate. The response time for this activity shall be fixed by the GNGPL / CONTRACTOR mutually. In case the house is found locked, then Contractor shall submit of House locked status and reattempt will be made after few days or by taking suitable time from customer on phone.

36 Hiring office for O&M services as per the scope given below.

For smooth operation & maintenance of CNG & PNG network already developed or being developed in various part of North Goa such as Ponda, Tiswadi, Bardez and other Thalukas, GNGPL intends to set up 01 nos fully furnished O&M office as and when required basis in following locations/ Which can be handle the whole operation of North Goa where GNGPL network is available.

The office space hired by successful bidders shall be such that it has good approach with accessibility by four wheelers and required parking space and shall present the good image of the company and have frontage to put board of GNGPL. The office space needs to be hired within max 45days from the date of intimation, GNGPL shall pay from the date office is occupied.

If Office Space is provided by GNGPL then, no office hiring charges will be payable to the contractor.

The following shall be silent feature of the O&M office:

- A) The minimum Carpet area of O&M office shall be approx. 1000sq.ft. The carpet area means area measured from wall to wall of the building. For area such as covered balconies etc., 50% of the area shall be considered and shall be added in overall carpet area. The other area such as stairs, lift as well as areas used for any other amenities shall not be considered for calculating carpet area of the offered office space and it is assumed that the quoted rate per month have been loaded accordingly.
- B) The office space hired by Contractor should preferably be on the main road with motorable road available and with proper approach. The premises should be visible from the main road. The office space hired should have minimum space for parking 4-6 Two-wheeler and 2 four-wheelers. The Contractor has to clearly state the detailed address with land mark of the office space. The offered premises shall be located in the areas mentioned in tender by GNGPL. Preliminary site visit of proposed office space shall be shown to GNGPL representative and if acceptable/suitable to GNGPL then only such office premises shall be hired.
- C) In case the offered space is located at above the ground+01floor, provision of elevator shall be provided by Contractor and there shall be no restriction for the transfer of service items / material in the elevator.

- D) The Contractor shall deploy one Attendant/office boy for day to day activities and up keeping of office, serving snacks/tea, photo copying & other associated services. The quoted rates shall include the charges for these services.
- E) Dedicated Parking space, preferably covered, for accommodating 02 nos. of Four wheelers (One ERV of type Tempo Traveler) and 3 Nos. of two wheelers shall be provided by the Contractor at the Hired office space. The rent quoted shall be inclusive of parking charges.
- F) The office shall have minimum 01 landline phone connection which will be displayed to customer to register any complaint or query. Similarly, office shall have internet connection to ensure communication between GNGPL office and O&M office. The Monthly payment towards these facilities are included in quoted price.
- G) Details of interior: The Office space hired shall be provide with good quality interiors and base interior plan shall be submitted to GNGPL for any modifications and after approval from GNGPL, the contractor shall proceed with execution of interiors. The interior work shall be according to company image and color scheme. The rates quoted shall be inclusive of interiors and furniture & no extra payment shall be paid.
- H) The Power back of adequate capacity shall be available for O&M office which can take care of PC, Fans, Lighting etc.
- I) All MCB shall be of adequate capacity considering total load of O&M office.
- J) 24hr water (both Normal & Drinking water treated with RO/Bottled Water) supply to Office premises shall be available.
- K) All tools and tackles required to carry out O&M activities shall be made available at O&M office.

The indicative utilization of carpet area and different items shall be as below:

Description	No	Total Area (sq.ft)	Purpose	Minimum facilities required.
Reception cum common area which shall be used by Visitor	1	100-120	To attend customer, call of the customer, collection of cheques to register complaints and to reply to the query of the new as well as existing customers.	PC with Windows 10 Operating system and latest configuration – 1 LASER printers cum Scanner-1 Nos Reception table with chair -01 Visitors steel fixed chairs:03-04 AC-01 Nos Area shall be adequately lighted.
Cubicle	3	120-150	01 cubicle for O&M supervisor 01 for GNGPL O&M Engineer	PC Windows 10 Operating system and latest configuration – 1 Nos each for each cubicle. LASER printers cum Scanner-1 Nos (To be used by all cubicle) Working table with Chair. Area should be air conditioned with proper light.

Work Stations	04	150-200	To be used by O&M Technician and Fire & Safety persons	Work stations with chair. Area should be properly lighted and ventilated with ceiling Fan.
Store Room cum documentation room	1	120-150	To be used for storing the Material required for O&M activities as well as to store O&M documents.	Fitted with Slotted Angles with panel Trays. Steel Almirah -02 Nos
Cabin Room	1	80-100	To be used by visiting GNGPL official.	Working Table -01 Executive chair-01 Visitors chair- 02 Area shall be properly lighted.
Toilet	2	100	Each one separately for Male & Female.	All the toilets are to be fitted with mirror, wash basins, EWC, soap dispenser, exhaust fan other accessories. of reputed make

The above area and quantities are indicative in nature and the actual quantities may vary.

Furniture / Fixture: The tables and chairs should be new and ergonomically designed. Provision of Grid false ceiling, particle board equivalent fixed on anodized aluminum grid, Anti-skid ceramic or vitrified tiled flooring and in-built cup boards for closed and open cabins. 24 Hour water supply, lighting fixtures for adequate illumination, Fans & other fittings. Power, Telephone, PC, are to be provided in all open and closed cabins. The above requirements are indicative only. However, the decision of GNGPL is final in deciding the plan / interior design / floor level / Chairs and Table.

- p. Air-conditioning: The Contractor is required to provide Air-conditioning system of his choice. Further, the Contractor should also ensure maintenance / upkeep of the same. In all closed rooms the Contractor shall also provide sufficient split / cassette ACs if required.
- q. Details of power load: Approved power load of 15 KVA is desirable. The power load is indicative. However, the Contractor should have required power for the office accommodation including for the interiors lighting, Computer Systems & peripherals, servers and Air-Conditioning load, elevator etc. Electricity charges for the leased premises shall be payable by Contractor.
- r. Power back up: The Contractor has to provide round-the-clock power back up for lighting, computers, fan etc. The billing for back-up power shall be payable by Contractor.
- s. Security Deposit: The Contractor shall pay security deposit for hiring of Office space.
- t. Insurance: The Contractor shall produce insurance for the Office space hired along with materials, equipment and goods within the hired Premises. covering riots, floods, tempest, fire, earthquake, all kinds of natural calamity, terrorist actions, etc., with the charges thereof being included in the Quoted Prices Lessee.
- u. General: Property tax / any other tax which is levied by Govt. of Goa shall be borne by the contractor of the premises only. GNGPL shall not pay any amount other than the quoted rate in the price bid.

- v. The quoted Rate for this SOR items shall include but not limited to the following and no additional charges shall be payable other than Quoted Rate:
 - A) Monthly rental charges
 - B) Brokerage Charges if any
 - C) Interior & Furniture, Fittings (Power, Data. Voice, Fans, Lights, etc.) / Furnishing charges
 - D) Advance Security Amount
 - E) Drinking Water and other water Charges
 - F) Parking Charges
 - G) Internet Provision
 - H) Electricity Charges
 - I) Back-up power& UPS charges
 - J) Maintenance Charges
 - K) Services for Attendant/Office Boy
 - L) Insurance & Property /Other charges
 - M) Registration/Other documentation charges
 - N) Computer & Other peripheral Charges
 - O) Any repair charges to the Property/ Furniture/Modifications.
 - P) All the stationary
 - Q) Any other charges to execute this SOR as per the Scope.
- w. The Payment shall be made under this SOR item on production of the following documents:
 - a. Copy of Lease Agreement with owner of the Property valid till the Contract Period / Occupied Period (one time). The purpose of lease shall be clearly mentioned in agreement i.e O&M office for GNGPL
 - b. Copy of Proof of Payment of Previous Months Rents & Other charges to the GNGPL.
- x. Due to any of the reasons, if the Contractor has to terminate the Lease agreement with the owner , then it is the responsibility of the Contractor to arrange for new Office premises as per the scope of the work under this SOR and any additional expenditure in arranging the same shall be in the scope of the Contractor before terminating the running Lease agreement for the hiring of Office Premises.
- y. Escalation: The rates under the scope of work are sought for each year. The First-year rates shall be applicable for 12 months from the date of Possession of the Office and subsequently for 2nd year of hiring of office. If the contract extends for 3rd year, a maximum of 10% escalation on 2nd year quoted rate or percentage increase of rent between contractor and owner (agreement) for 3rd year from 2nd year value whichever is less shall be provided,
- z. The Contractor shall use the Premises for office purposes only and shall not carry on or permit to be carried on in the Leased Premises, or in any part thereof, any activities which are unlawful, obnoxious, or of nuisance, annoyance or disturbance to other tenants / occupants in the Building.
- aa. Signage: The Contractor shall display GNGPL own signs, name plates, logos and signboards on the building directory and the Leased Premises with proper

illumination. No extra charges shall be payable. The Contractor shall be responsible for securing all requisite permissions and approvals for putting up such signage. The Lessee shall remove all such signage on the expiry or sooner termination of this Agreement.

- bb. Various types of customers shall be visiting the Office premises for issues related to GNGPL business. The Office premise and its team should treat them very well.
- cc. Indemnity: The Contractor shall indemnify, and keep indemnified GNGPL employees from and against any claim, liability, demand, loss, actions, proceedings, damage, judgment or other obligation or right of action, which may arise due to non-compliance with any statutory requirements or defect in title in respect of the Leased Premises leading to occupation being disturbed, interrupted or hampered in any manner whatsoever. The Contractor will indemnify and keep GNGPL indemnified against all claims, losses, damages and costs (excluding any direct or indirect business losses) incurred by the Lessor in respect of the Leased Premises due to or due to non-payment of statutory tax liability or payments of any nature arising out of business of GNGPL in the Leased Premises and payable by the Contractor or by reason of any act or deed or omission in relation to the Leased Premises.

Penalty: If the office is not provided within 45 days from the date of intimation, penalty of Rs 1000/office/day of delay shall be applicable

The scope and description shall remain same for above item as described earlier.

37 Hiring of Maintenance Van for Operation and Maintenance Office.

For handling emergency calls and carrying out various planned operation and maintenance activities, of the city gas distribution system, availability of well-equipped vehicle called normally as maintenance van is very important. Contractor has to deploy one Maintenance Vehicle for each O&M office for 24hrs services basis, for attending the Emergency works and other routine jobs as per the instructions given below:

- a. The four-wheeler shall be of 5-seater Mahinda Bolero camper 4WD or equivalent model/make having open space available at the backside. The back side shall be customized as per the drawing with proper racks for keeping equipment / tools/tackles required for emergency response in O&M activities of CGD network. The vehicle should be capable of taking the maintenance team to sites along with Tools & equipment. The same shall be converted into Maintenance Van with GNGPL branding.
- b. The Maintenance Van shall be deployed within 45 days of intimation from GNGPL for round the clock operation along with driver (proper License Holder), fuel, suitable RTO permission, Insurance and other requirements as per the Transport Authority.
- c. The rate for this SOR shall be for 2500 km per month and Extra km run beyond 2500 km shall be paid as per the other SOR item. No extra charges shall be paid for Parking, construed to be included in the quoted price.

d. All charges towards the running cost of vehicle shall be borne by contractor. GNGPL shall not make any payment other than quoted price in SOR

CONTRACTOR shall provide emergency vehicle along with Accessories and the vehicle shall be used and must be kept in a good working conditions all the time. Driver to be deployed on this vehicle must be well trained / experienced, non-alcoholic or drug addict & dressed in approved uniform. Necessary manpower, machine / equipment's, spares / materials & consumables shall be arranged by CONTRACTOR for any emergency.

Standard reasonable load carrying vehicle, with open truck type body and good maneuverability that can be converted into maintenance van, after building customized body for storage and security of various tools tackles, pipes and fittings, fire extinguishers etc. generally required for handling gas leak / escape emergencies and routine and break down maintenance of network and installations, from city gate station to customer connections, located near and far.

For highlighting the company identity, the van is painted with company logo, name, and contact telephone numbers & special colour approved by GNGPL in special colour and pictures, beautifying it with aesthetic look.

For monitoring the vehicle movement, Contractor should mandatory fit into the Emergency vehicle Tracking System (VTS). If VTS is not working properly, the same shall be informed by CONTRACTOR to GNGPL immediately.

Any detour away from the scheduled route / route to be followed for attending maintenance activities cannot be considered as a part of the additional KM charges to be paid.

Maintenance van all required items is very important, and hence should be operated and maintained with utmost care. The van should be used only for intended purpose. Ensure driving of the van with lawful and traffic safety, taking care of the damaging bumps on the road. The regular checks and inspection procedure should be established, assigning responsibility to particular shift engineer. The vehicle should be checked daily in the morning, as per the check list, having checks for, tire pressure, engine oil, fuel level, other abnormalities like over temperature, vibration, noise etc. including announcement and wireless system.

The vehicle should be regularly serviced in a good equipped garage. Similarly, the tools tackles should be checked every month end to ensure the availability and working condition of each item. The effective material reconciliation procedure and check list should be prepared to ensure the availability of pipes and fittings and replacements for the consumed pipes and fittings. The replacement for the use / lost items should be done immediately otherwise there are chances of forgetting the replacement.

The fire extinguisher and pressure gauges, torches, stored in the van, should be periodically checked and calibrated for their working. For overall security of all items, the van should always be locked and guarded, when not in use.

At Maintenance van should be parked at safe and secured place, keeping watch. Take out the required items only, do not remove / take out unwanted items, from the van. Return back the items in van immediately after completion of job. Ensure that all items are collected

and returned back in the van to their respective place, after repeatedly looking outside, here and there.

CONTRACTOR shall maintain the day-to-day records & submit it along with monthly reports.

Vehicle should be maintained in proper working conditions throughout the tenure of the contract by carrying out preventive, periodic & breakdown maintenance as per Manufacturer's recommendations. CONTRACTOR shall submit the report on such scheduled or breakdown maintenance performed from time to time. All the inspection & maintenance should be carried out by authorized dealers only.

CONTRACTOR shall make an alternate arrangement in case of Routine, Periodic maintenance to be carried out or for RTO purpose, required from time to time at his own cost & risk. GNGPL shall ensure that in such case the O&M is not affected.

Any penalty for non-compliance or delay in compliance of statutory matters shall be realized / recovered from CONTRACTOR.

CONTRACTOR shall ensure the validity of driving license for the driver deployed on vehicle at his own cost.

CONTRACTOR shall be solely responsible for any accident of vehicle & caused damages to vehicle or the property of third party or the human (injury or death). Such cost shall be recovered from CONTRACTOR & any complaints in police or competent authorities in this regard shall be taken up at his cost & risk including insurance claim, repairing of vehicle, damage to third party.

The Maintenance Van shall be equipped with minimum critical equipment to handle the emergency. The list of minimum critical equipment/tools is as under:

Sr.No	Brief Description of Equipment /Tools	UoM	Qty.
1	PE Hydraulic/Manual Steel Squeezer (63mm to 125mm)	Nos	2
2	PE Manual Steel Squeezer (32mm to 90mm)	Nos	2
3	PE Manual Squeezer (20mm to 32mm)	Nos	2
4	PE Pipe cutter (20mm to 125mm)	Nos	2
5	Universal Alignment Clamp 32mm to 125mm	Nos	2
6	Manometer (0-200 mm) Mercury	Nos	2
7	Digital Pressure Gauge (bar, psi, mbar),0-500 mbar, 0 to 10 bar	Nos	1
8	Manual Jack up to 5Ton	Nos	1
9	LED Flood Light of 50 w with Wire & Plug/Socket/MCB Arrangement with Extension up to 15 m.	№	1
10	Digging Spade/Shovel, Spear Set for excavation	№	2
11	Dewatering Pump	№	1
12	Barricading Tapes/Chains/Cones	Set	Sufficient
13	Other tools & Tackles, Consumables for attending emergency Pipeline damages & Maintenance works.	Sufficiently	

The contractor shall keep arrangement for 01 fusion machine and portable generator for each O&M office.

The records for tools & equipment shall be updated every fortnight. Any minor maintenance for the equipment shall be carried out by the contractor periodically. At least once in a month, security / test run shall be carried out and recorded by the contractor. The consumables viz. petrol / diesel, other lubricants consumables for operation of DG set etc. during test run and at site while attending jobs shall be in the scope of the contractor. The rates quoted shall include these miscellaneous expenditures.

Penalty:

- i. If the vehicle is not deployed within a 45days after intimation a penalty of Rs1000/vehicle/day delay.
- ii. If the vehicle it is not available on any day due to breakdown a penalty of 2*cost of vehicle per day as per SOR shall be applicable.

TENTATIVE SKECH OF MAINTENANCE VEHICLE

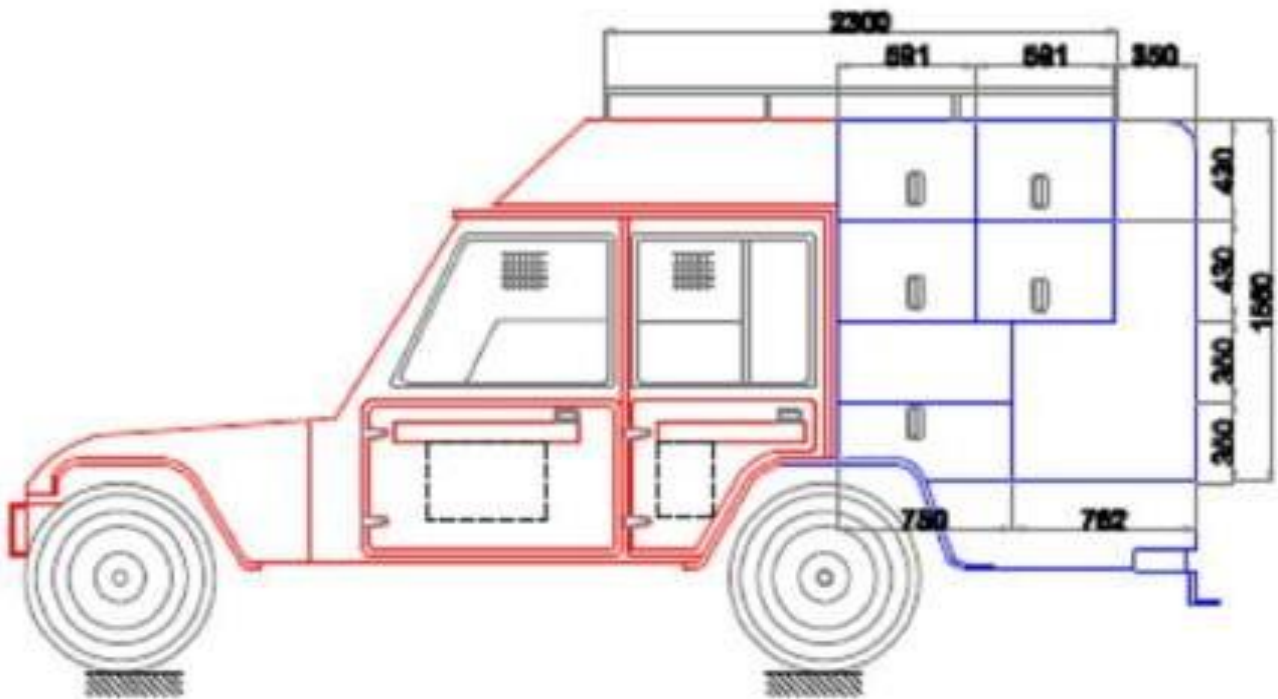

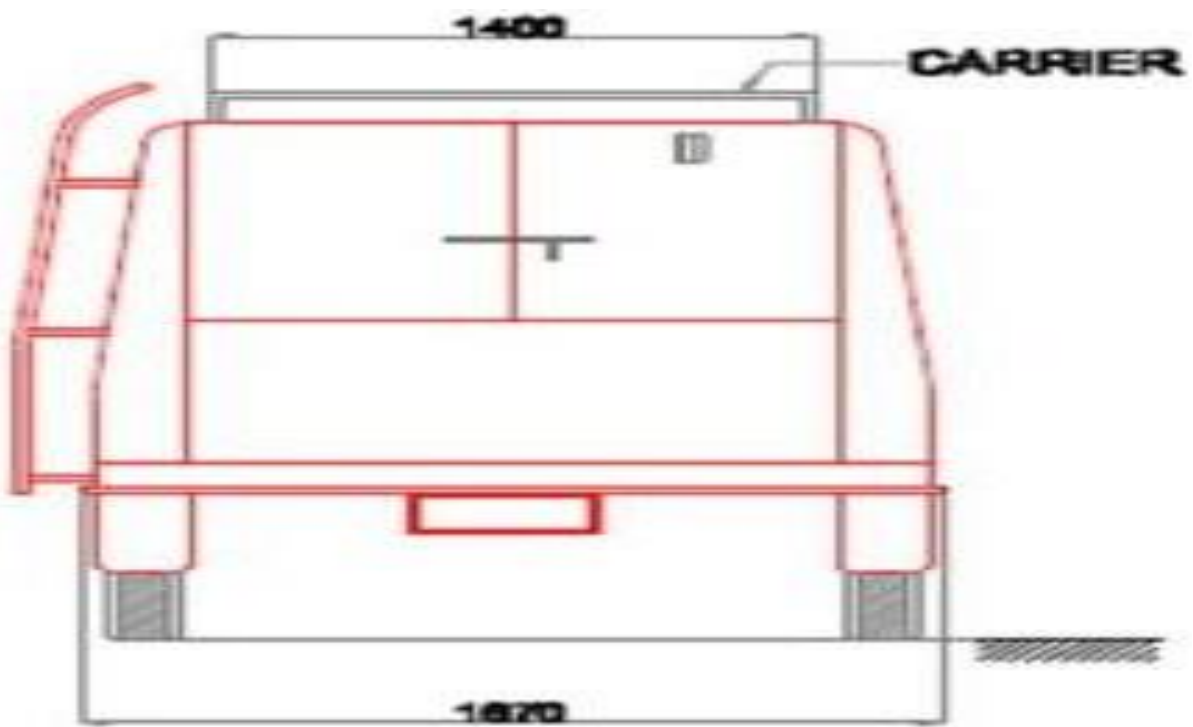
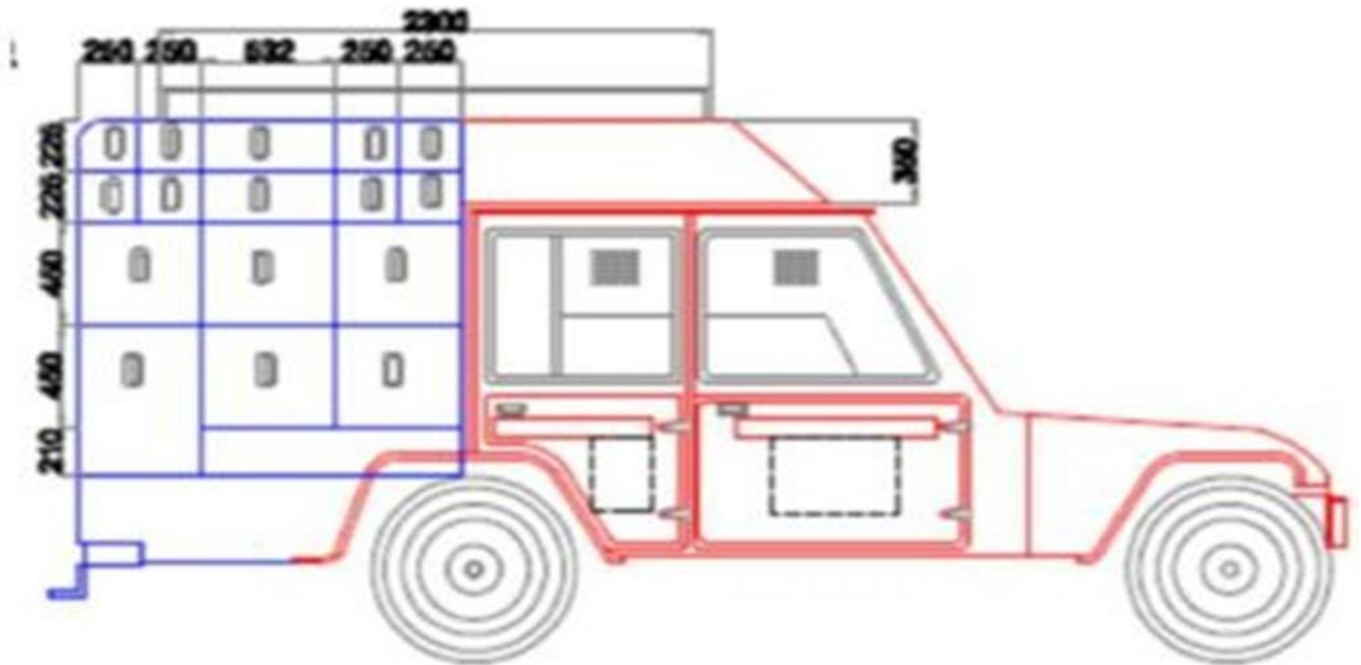

LIST OF MINIMUM ITEMS FOR FIRST AID BOX UNDER CONTRACTOR'S SCOPE

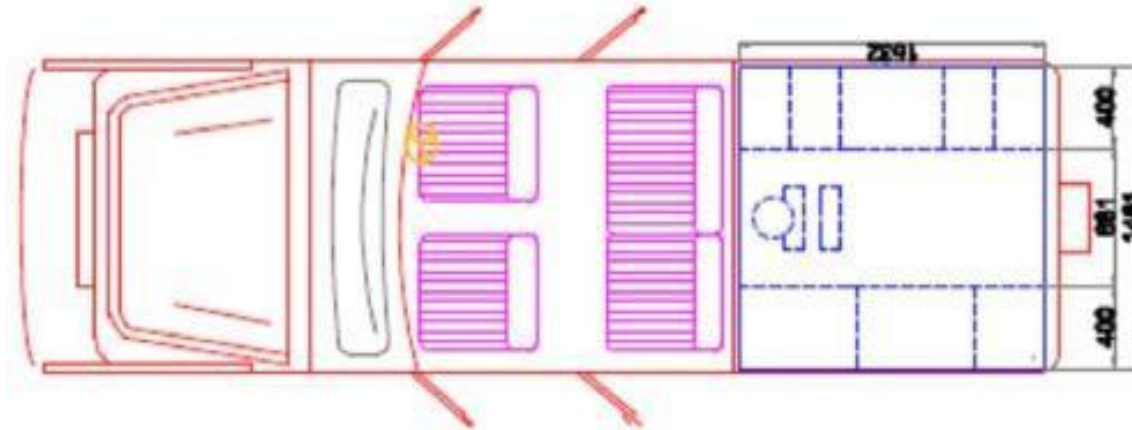

Sr No.	Item Description	Qty
1.	Small Dressing Gauze Swab for Finger Wound	8
2.	Medium Dressing Gauze Swab for Hand or Feet Wound	8
3.	Large Dressing Gauze Swab for Body Wound	8
4.	Soframycin Cream Tube, 15 Gram	1
5.	Bottle Of Antiseptic Solution 100 ml. Each	1
6.	Absorbent Cotton Wool I.P 20 Gram	4
7.	Roll of Adhesive Paster 2.5 CM X 1Mt U.S.P	1
8.	Bandage Rolled (5CM X 2 Mter)	9
9.	Eye Pad Each in Pkt (Sterile)	7
10.	Strip of 10 Tablet Paracetamol I.P 0.5 Gram	10
11.	Potassium Permagnate I.P 20 Gram	1
12.	Boric Acid I.P 20 Gram	1
13.	Band Aid Strip	5
14.	Dressing scissor 5" Stainless Steel	1
15.	Polythene Wash Bottle 250 CC For washing Eye	1
16.	Tourniquet Cotton Belt & Buckle	1
17.	Eye Wash Cup	1
18.	Safety Pins	12
19.	Spray for Burn Injury (100 ml)	1
20.	Spray for Muscle Sprain (Relispray) (100 ml)	1
21.	Spray Antisaptic Bandage (100 ml)	1

LIST OF MINIMUM MANDATORY SAFETY EQUIPMENTS & PPE'S

Sr. No.	Name Of Material
1	Fire Extinguisher, DCP/CO2 Type 5 & 10 Kg each, ISI mark
2	Safety Helmets
3	Headlamp with LED light
4	Electric shockproof Hand Gloves
5	Safety Goggles
6	Ear Plug
7	Traffic cone
9	Warning Tape
10	Folding Stretcher (Thadani)
11	Fluorescent Jacket
12	Flameproof Emergency Torch
13	Rope with safety belts
14	Gum Boots
15	Rain Coat
16	Winter safety wear
17	First-Aid Box

List of Approved Make for O&M services at GNGPL

Sr No	Item	Approved Make
1	MDPE Valve	George Fisher, Agru
2	MDPE Fittings	George Fisher, Kimplas
3	Warning Tape	Sparco, Singhal
4	GI pipes	Indus tube, Jindal Hissar, Surya Rsohni,Swastik pipe,Appolo tubes
5	GI Fittings	Jainsons Industries, Jinan Medie,Jupiter Metal
6	Copper pipes & Fittings	Jayna , Chandan Enterprises, Paras Industires, Rajco Metalm Mehta Tubes
7	Isolation Value & Appliance Valve	Jinan Meide, Jainson Industires, Universal Srl, Fratelli Fortis
8	Surakaha hose	Suraksha Product pvt Ltd, Vikram, Gayatri, Luxmi Rubtech

List of Minimum Inventory to be maintained by Contractor at any point of time at each O&M office during the contract period.

Note: All PE Fittings shall be PE 100 SDR as applicable and black color.

Sr No	Name of Material	UOM	Make	Minimum QTY
A	PE Pipes, Electro Fusion Fitting& it's related materials			
1	PE Coupler 125 mm	Nos.	Georg Fischer (GF)	5
2	PE Coupler 90 mm	Nos.	Georg Fischer (GF)	5
3	PE Coupler 63 mm	Nos.	Georg Fischer (GF)	5
4	PE Coupler 32 mm	Nos.	Georg Fischer (GF)	10
5	PE Coupler 20 mm	Nos.	Georg Fischer (GF)	10
6	PE Elbow 125 mm (90 Deg)	Nos.	Georg Fischer (GF)	2
7	PE Elbow 90mm (90 Deg)	Nos.	Georg Fischer (GF)	2
8	PE Elbow 63mm (90 Deg)	Nos.	Georg Fischer (GF)	4
9	PE Elbow 32 mm(90 Deg)	Nos.	Georg Fischer (GF)	10
10	PE Elbow 20 mm(90 Deg)	Nos	Georg Fischer (GF)	10
11	PE Elbow 125 mm (45 Deg)	Nos.	Georg Fischer (GF)	3
12	PE Elbow 90mm (45 Deg)	Nos.	Georg Fischer (GF)	3
13	PE Elbow 63mm (45 Deg)	Nos.	Georg Fischer (GF)	5
14	PE Elbow 32 mm(45 Deg)	Nos.	Georg Fischer (GF)	2
15	PE Equal Tee 125mm	Nos.	Georg Fischer (GF)	2
16	PE Equal Tee 90mm	Nos.	Georg Fischer (GF)	2
17	PE Equal Tee 63mm	Nos.	Georg Fischer (GF)	2
18	PE Equal Tee 32mm	Nos.	Georg Fischer (GF)	5
19	PE Equal Tee 20mm	Nos.	Georg Fischer (GF)	5
20	PE Reducer 125mm x 90mm	Nos.	Georg Fischer (GF)	2
21	PE Reducer 125mm x 63mm	Nos.	Georg Fischer (GF)	2
22	PE Reducer 90mm x 63mm	Nos.	Georg Fischer (GF)	2
23	PE Reducer 63mm x 32mm	Nos.	Georg Fischer (GF)	5
24	PE Reducer 32mm x 20mm	Nos.	Georg Fischer (GF)	5
25	PE Saddle125mm x 90mm	Nos.	Georg Fischer (GF)	2
26	PE Saddle 125mm x 63mm	Nos.	Georg Fischer (GF)	2
27	PE Saddle 90mm x 63mm	Nos.	Georg Fischer (GF)	2

28	PE Saddle 125mm x 32mm	Nos.	Georg Fischer (GF)	2
29	PE Saddle 90mm x 32mm	Nos.	Georg Fischer (GF)	2
30	PE Saddle 63mm x 32mm	Nos.	Georg Fischer (GF)	2
31	PE Saddle 90mm x 20mm	Nos.	Georg Fischer (GF)	2
32	PE Saddle 63mm x 20mm	Nos.	Georg Fischer (GF)	2
33	PE Saddle 32mm x 20mm	Nos.	Georg Fischer (GF)	2
34	PE End Cap 125mm	Nos.	Georg Fischer (GF)	2
35	PE End Cap 90mm	Nos.	Georg Fischer (GF)	2
36	PE End Cap 63mm	Nos.	Georg Fischer (GF)	5
37	PE End Cap 32mm	Nos.	Georg Fischer (GF)	5
38	PE End Cap 20mm	Nos.	Georg Fischer (GF)	5
39	Transition Fitting 1/2"x 20mm	Nos.	Georg Fischer (GF)	5
40	Transition Fitting 1/2"x 32mm	Nos.	Georg Fischer (GF)	5
41	Transition Fitting 3/4"x 20mm	Nos.	Georg Fischer (GF)	5
42	Transaction Fitting 3/4"x 32mm	Nos.	Georg Fischer (GF)	5
43	Stop Up Valve 125 mm	No.s	Georg Fischer (GF)	2
44	Stop Up Valve 90 mm	No.s	Georg Fischer (GF)	2
45	Stop Up Valve 63 mm	No.s	Georg Fischer (GF)	2
46	Pre Cast RCC Valve Chamber cover with frame as per Bid Drawing	Nos	Approved Make	4
B	G.I. Consumable Material list			
1	GI 1/2" Powder coated Pipe, C-Class	Mtr	Approved vendor	20
2	GI 3/4" Powder coated Pipe, C-Class	Mtr	Approved vendor	20
3	GI 1" Powder coated Pipe, C-Class	Mtr	Approved vendor	10
4	Ball Valve (MCV/IV-1/2")	Nos.	Approved vendor	10
5	Ball Valve (MCV/IV-3/4")	Nos.	Approved vendor	10
6	Ball Valve (MCV/IV-1")	Nos.	Approved vendor	10
7	GI 1/2" Powder coated Coupling	Nos.	Approved vendor	10
8	GI 3/4" Powder coated Coupling	Nos.	Approved vendor	10
9	GI 1" Powder coated Coupling	Nos.	Approved vendor	5
10	GI 1/2" Powder coated Union	Nos.	Approved vendor	10
11	GI 3/4" Powder coated Union	Nos.	Approved vendor	5
12	GI 1" Powder coated Union	Nos.	Approved vendor	2
13	GI 1/2" Powder coated Elbow	Nos.	Approved vendor	10
14	GI 3/4" Powder coated Elbow	Nos.	Approved vendor	5
15	GI 1" Powder coated Elbow	Nos.	Approved vendor	2
16	GI 1/2" Powder coated Plug	Nos.	Approved vendor	10

17	GI 3/4" Powder coated Plug	Nos.	Approved vendor	10
18	GI 1" Powder coated Plug	Nos.	Approved vendor	5
19	GI 1/2" Powder coated Equal Tee	Nos.	Approved vendor	5
20	GI 3/4" Powder coated Equal Tee	Nos.	Approved vendor	5
21	GI 1" Powder coated Equal Tee	Nos.	Approved vendor	2
22	GI 1" x 1/2" Powder coated Unequal Tee	Nos.	Approved vendor	2
23	GI 3/4" x 1/2" Powder coated Unequal Tee	Nos.	Approved vendor	2
24	GI 1" x 1/2" Powder coated Reducer	No's	Approved vendor	2
25	GI 3/4" x 1/2" Powder coated Reducer	No's	Approved vendor	5
26	MALE FEMALE elbow 1/2" Powder coated	No's	Approved vendor	10
27	GI 1" Powder coated Clamp with screw and proper pad	Nos.	Standard Make	10
28	GI 3/4" Powder coated Clamp with screw and proper pad	No's	Standard Make	20
29	GI 1/2" Powder coated Clamp with screw and proper pad	No's	Standard Make	50
30	GI 1" Nipple 1"x2"	Nos.	Standard Make	10
31	GI 1" Nipple 1"x3"	Nos.	Standard Make	10
32	GI 1" Nipple 1"x4"	Nos.	Standard Make	10
33	GI 1" Nipple 1"x6"	Nos.	Standard Make	10
34	GI 3/4" Nipple 3/4"x2"	Nos.	Standard Make	10
35	GI 3/4" Nipple 3/4"x3"	Nos.	Standard Make	10
36	GI 3/4" Nipple 3/4"x4"	Nos.	Standard Make	10
37	GI 3/4" Nipple 3/4"x6"	Nos.	Standard Make	10
38	GI 1/2" Nipple 1/2"x2"	Nos.	Standard Make	10
39	GI 1/2" Nipple 1/2"x3"	Nos.	Standard Make	10
40	GI 1/2" Nipple 1/2"x4"	Nos.	Standard Make	10
41	GI 1/2" Nipple 1/2"x6"	Nos.	Standard Make	10
42	Powder coated Meter Bracket	Nos	Standard Make	10
C	Copper Consumable Material List			
1	12 mm copper pipe	Mtr	Approved vendor	30
2	12 mm copper coupler (PRE SOLDERED)	Nos.	Approved vendor	10
3	12 mm copper elbow (PRE SOLDERED)	Nos.	Approved vendor	5
5	O Ring/Seal for Union	Nos.	Approved vendor	10
6	O ring washer for regulator adapter	Nos.	Approved vendor	10
7	O ring washer for meter adapter G-1.6	Nos.	Approved vendor	10
8	Brass Disconnecting Union (3/4" BSPT x 12mm, Straight)	Nos.	Approved vendor	10
9	Brass Disconnecting Union (1/2" BSPT x 12mm, Straight)	Nos.	Approved vendor	10
10	Brass Adopter (1/4" BSPT x 12mm, Straight)	Nos.	Approved vendor	10
11	Meter Inlet Union (3/4" x 3/4")	Nos.	Approved vendor	10
12	Meter Outlet Union (3/4" x 12mm, Straight)	Nos.	Approved vendor	10
13	Suraksha Rubber Tube, Wire Braided (1 mtr. Long, IS 9573 part IV)	Mtr.	Approved vendor	20
14	Rubber Hose Clamp	Nos.	Standard Make	30
15	Rawal Plug	Nos.	Standard Make	200
17	S.S Screw	Nos.	Standard Make	200
18	12 mm copper pipe PVC clamp type 2	Nos.	Standard Make	50

19	SOLDER JOINT(WIRE)	Grams.	Standard Make	500
20	FLUX (NON ACIDIC LEAD FREE)	Grams.	Standard Make	500
21	BLOW LAMP (BUTANE GAS CARTRIDGE)	Nos.	Standard Make	1
22	Appliance valve (1/2" NPT)	Nos.	Approved vendor	5
23	Commercial meter adaptor (All size)	SET	Approved vendor	1

Technical Specifications and Drawings:

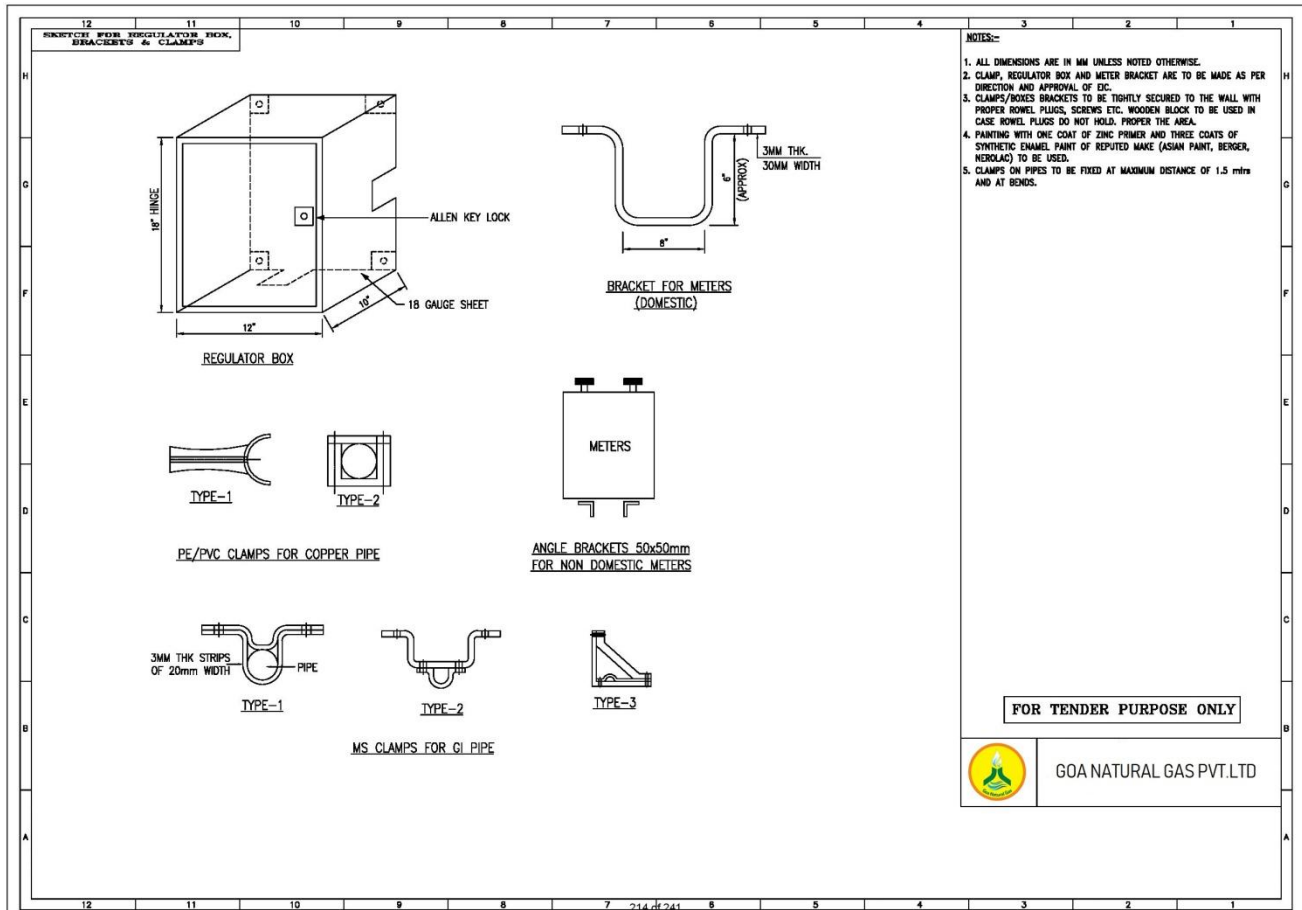

- NOTES:-**
1. ALL DIMENSIONS ARE IN MM UNLESS NOTED OTHERWISE.
 2. CLAMP, REGULATOR BOX AND METER BRACKET ARE TO BE MADE AS PER DIRECTION AND APPROVAL OF E.C.
 3. CLAMPS/BOXES BRACKETS TO BE TIGHTLY SECURED TO THE WALL WITH PROPER ROWEL PLUGS, SCREWS ETC. WOODEN BLOCK TO BE USED IN CASE ROWEL PLUGS DO NOT HOLD. PROPER THE AREA.
 4. PAINTING WITH ONE COAT OF ZINC PRIMER AND THREE COATS OF SYNTHETIC ENAMEL PAINT OF REPUTED MAKE (ASIAN PAINT, BERGER, NEROLAC) TO BE USED.
 5. CLAMPS ON PIPES TO BE FIXED AT MAXIMUM DISTANCE OF 1.5 mtrs AND AT BENDS.

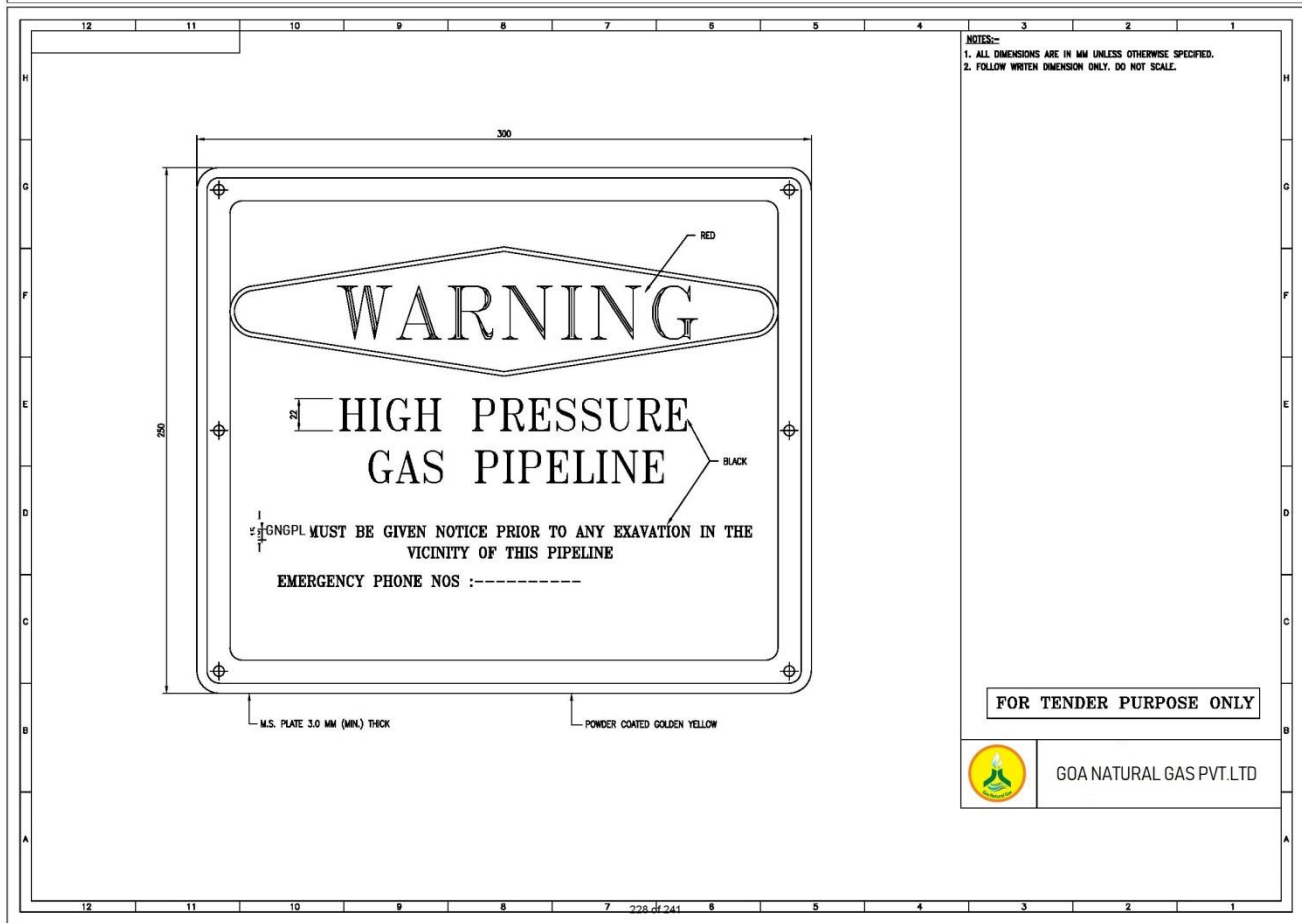

- NOTES:-**
1. ALL DIMENSIONS ARE IN MM UNLESS OTHERWISE SPECIFIED.
 2. FOLLOW WRITTEN DIMENSION ONLY. DO NOT SCALE.

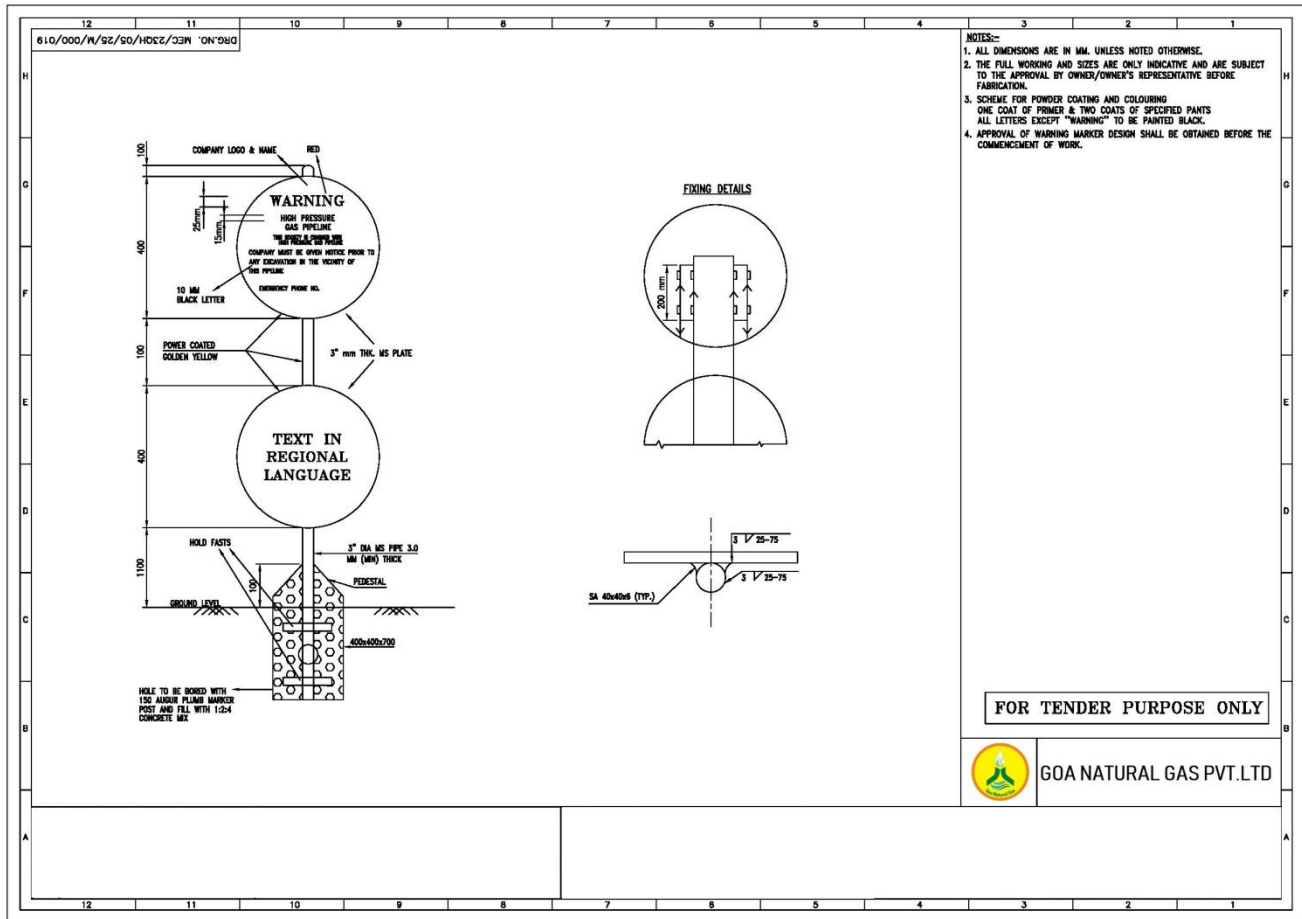

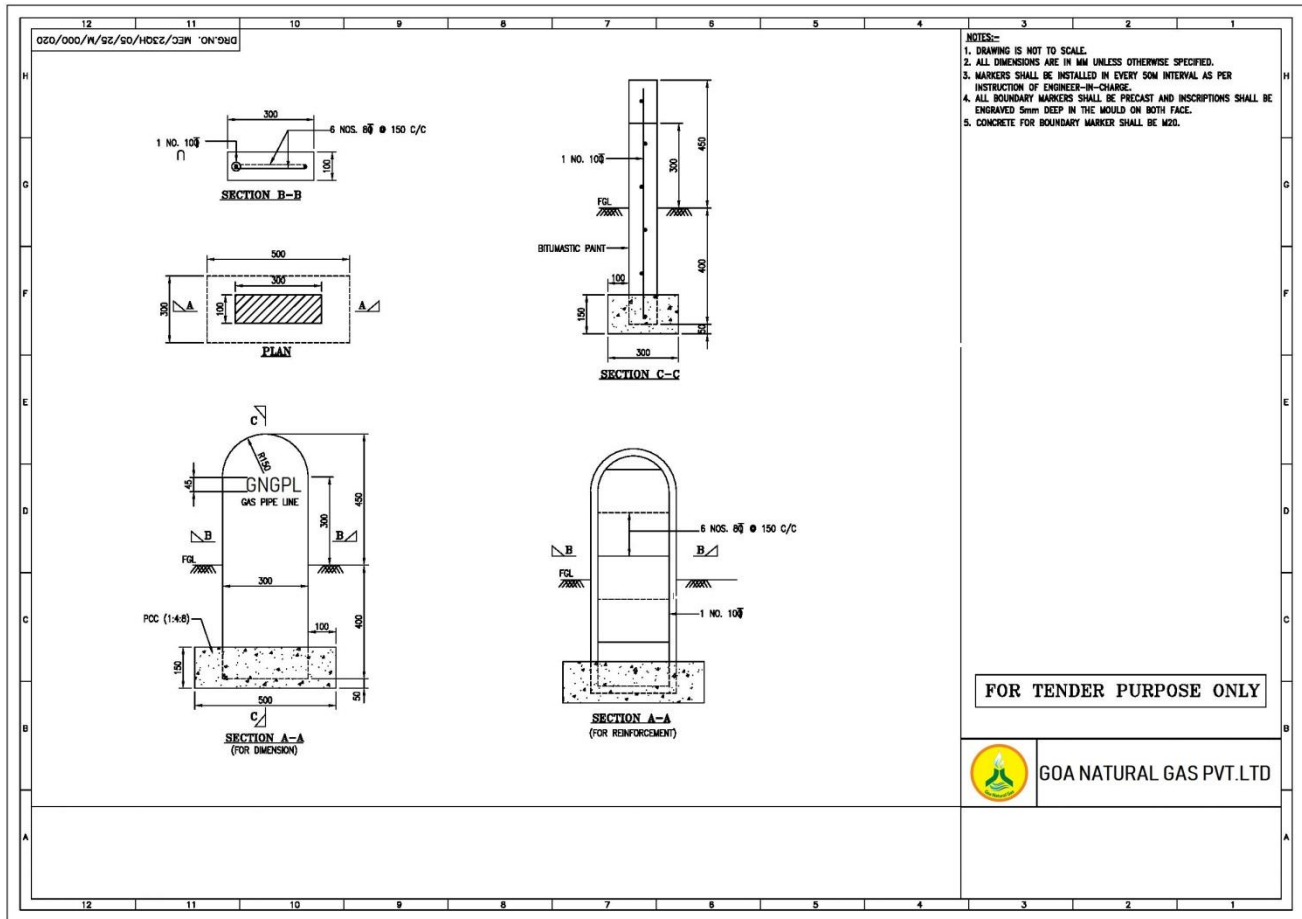

Details for Bought Out Items

1. **Inspection / Documents for Supply Items:** Contractor has to supply materials of approved make in the vendor approved list mentioned in the tender. Contractor shall supply the invoice at the time of submitting the Material Receipt Voucher (MRV). Valid TPIA report shall be submitted when GNGPL ask to submit. Vendor shall furnish all the material test certificates, proof of approval/ license from specified authority as per specified standard, if relevant, internal test / inspection reports as per GNGPL Ltd Technical Specification and specified code for 100% material, at the time of final inspection of each supply lot of material. Even after third party inspection, GNGPL Ltd reserves the right to Select a sample of tube randomly from each manufacturing batch and have these independently tested. Should the results of these tests fall outside the limits specified in GNGPL Ltd Technical specification, then GNGPL Ltd reserves the rights to reject all production supplied from the batch.

2. **Technical Specification for GI pipes:**

Service	Natural Gas
Working Pressure	4 bar (g)
Test Pressure	6 bar (g)
Working Temperature	0°C to 50°C
Material Description	IS: 1239 (Part-I) Heavy Duty, Continuous Welded
Min. Tensile Strength	30 kgf/sq.mm
Min. Elongation	6%
Tolerance	+ Not limited, - 10%
Protective Coating	Galvanized uniformly to protect from corrosion as per IS:4736/ASTM A53 or by Electro Galvanizing
Ends of Pipes	Plain End
Inspection	100% Pressure Testing shall be carried out at factory

2.1. **General Notes:** All pipes and their dimensions, tolerance, chemical composition, physical properties, heat treatment, hydro test and other testing and marking shall conform to the codes and standards. Material test certificates (physical property chemical composition & heat treatment report) shall also be furnished for the pipes supplied. Pipe shall be supplied in single or double random length of 4 to 7 and 7 to 14meters respectively. Galvanized pipes shall be coated with zinc by hot DLF process conforming to IS:4736/ ASTM AS3 or by electro galvanizing. Zinc conforming to any grade specified in IS 13229-1991 with latest amendment shall be used for the purpose of galvanizing. The molten metal in the galvanizing bath shall contain not less than 98.5 % by mass of Zinc. Minimum mass of Zinc coating determined as per IS:6745 shall be 360 gm/m². The galvanized coating when

determined on a 100mm long test piece in accordance with IS 2633: 1986 with latest amendments shall withstand 5 one-minute dips. The Zinc coating on internal and external surfaces shall be uniform adhered reasonably smooth and free from such imperfection as flux, ash and drop inclusion, bare patches, black spots, lumpiness runs, rust stains, bulky white deposits and blisters. Rejection and acceptance of these defects shall be in accordance with Appendix A of IS 2629: 1985 with latest amendments.

2.2. **Marking and Dispatch:** All pipes shall be marked in accordance with the applicable codes, standards and specifications. Paint or ink for marking shall not contain any harmful metal or metallic salts, such as Zinc Lead or Copper which causes corrosive attack in heat. Pipes shall be dry, clean and free from moisture, dirt and loose foreign materials of any kind. Pipes shall be protected from rust, corrosion and mechanical damage during transportation, shipment and storage. Steel end protectors to be used on galvanized pipes, shall be galvanized. Both ends of the pipe shall be protected with the following material.

Plain End : Plastic Cap
 Bevel End : Wood, Metal or Plastic Cover
 Threaded End : Metal or Plastic Threaded Cap

2.3. **Packing:** Packing size to be mentioned to ensure uniformity in delivery condition of the material being procured. Contractor shall submit the packaging details during QAP and also compiled with at the time delivery.

3. Technical specification for copper pipes:

Service	Natural Gas
Working Pressure	300 mbar (g)
Hydrostatic Test Pressure	35 bar (g) for 10 sec as per EN 1057(latest)
Working Temperature	0°C to 50°C
Material Description	BS EN 1057 (latest) grade Cu - DHP or CW024A
Min. Tensile Strength	250 N/sq.mm
Min. Elongation	30%
Tolerance	+ .5mm, - 0
Chemical Composition	Cu % including silver: Min 99.9 % Phosphorus %: 0.015 to 0.040%
Manufacture	The tubes shall be solid drawn by the process of melting, extrusion and thereafter bright annealing. The ends shall be cut clean and square with the axis of the tube in no case shall tubes be redrawn from old or used tubes
Inspection	100% Pressure Testing shall be carried out at factory
Size	12 mm

3.1. **General Notes:** All pipes and their dimensions, tolerance, chemical composition, physical properties, heat treatment, hydro test and other testing and marking shall conform to the codes and standards. Material test certificates (physical property

chemical composition & heat treatment report) shall also be furnished for the pipes supplied. Pipe shall be supplied in single length of 3 meters respectively. Freedom from defect: The tubes shall be free from internal and external fins, flaws skin defects, blowholes, etc. or other irregularities which might restrict the free flow of fluid and shall be so designed that resistance to the flow of fluid through the tubes is minimized. All tubes will be supplied 100 % Eddy current tested as per ASTM E243 and BS EN 1057. Eddy current testing is a computer aided test, wherein the tubes pass through a probe and an electromagnetic field is created around the peripheral of the tube to detect any flaw or blow hole which may not visible to the naked eye. The manufacturer must have in house Eddy current testing facilities to supply to GNGPL.GNGPL reserve right to witness the Eddy current facility at the manufacture's factory premises. Drift Expanding Test: Drift expanding test shall be carried out as per EN 1057. The OD of the tube end shall be expanded by 30% using a conical mandrel (at angle 45⁰) with no wrinkles, cracks, break, or any form of defect should occur on the tube during test & after the test. Carbon Film Test: Cu tubes to be tested for carbon film test and the manufacture will certify that the tubes meet requirement of clause 8.5 of BS EN 1057. Carbon Content Test: Cu tubes to be tested of carbon content test to ensure a carbon level to avoid the formation of carbon film during installation. Max carbon level shall be permitted as per clause 6.5 of BS EN 1057.

- 3.2. **Marking and Dispatch:** All pipes shall be marked in accordance with the applicable codes, standards and specifications. Paint or ink for marking shall not contain any harmful metal or metallic salts, such as zinc lead or copper which causes corrosive attack in heat. Pipes shall be dry, clean and free from moisture, dirt and loose foreign materials of any kind. Pipes shall be protected from corrosion and mechanical damage during transportation, shipment and storage.
- 3.3. **Packing:** Packing size to be mentioned to ensure uniformity in delivery condition of the material being procured. Contractor shall submit the packaging details during QAP and also compiled with at the time delivery.

4. Technical Specification for GI Fittings:

Service	Natural Gas
Working Pressure	4 bar (g)
Pressure Test	As per Clause 11.1b of IS:1879-1987 with latest amendment on each and every fittings
Working Temperature	0°C to 50°C
Material Description	IS:14329-1995, latest amendments Grade BM 300
Tolerance	As per IS 1879 -1987 with latest amendments
Protective Coating	Fitting should be galvanized as per IS:4759 -1996 with latest amendments
Weight	As per section 2-10 of IS:1879- 1987 with latest amendments
Inspection	100% Pressure Testing shall be carried out at factory

Thread Type	NPT type conforming to ASME B1.20.1 (External & internal threads shall be tapered. The outlet fittings shall be chamfered.)
Size	12 mm

- 4.1. **General Notes:** All fittings and their dimensions, tolerance, chemical composition, physical properties, heat treatment, hydro test and other testing and marking shall conform to the codes and standards. Material test certificates (physical property chemical composition & heat treatment report) shall also be furnished for the fittings supplied. Zinc conforming to any grade specified in IS 13229-1991 with latest amendment shall be used for the purpose of galvanizing. Galvanizing bath: The molten metal in the galvanizing bath shall contain not less than 98.5 % by mass of zinc. Mass of zinc coating: Minimum mass of zinc coating determined as per IS:6745 shall be 610 - 700 gm/m². The zinc coating on internal and external surfaces shall be uniform adhered reasonably smooth and free from such imperfection as flux, ash and drop inclusion, bare patches, black spots, lumpiness runs, rust stains, bulky white deposits and blisters. Rejection and acceptance of these defects shall be in accordance with Appendix A of IS 2629: 1985 with latest amendments.
- 4.2. **Pressure Test:** Vendor shall carry out pneumatic pressure test as per clause 11.1b of 1879- 1987 with latest amendments on each and every fitting. Vendor to submit the internal quality control certificate for the same. GNGPL shall witness pneumatic testing as per the sampling procedure specified in 1879 with latest amendments.
- 4.3. **Compression Test:** The test shall be conducted to judge the malleability of the pipe fittings and shall be carried out as per clause 12 of 1879-1987 with latest amendments.
- 4.4. **Marking and Dispatch:** All fittings shall be marked in accordance with the applicable codes, standards and specifications. Paint or ink for marking shall not contain any harmful metal or metallic salts such as zinc lead or copper which causes corrosive attack in heat. All fittings shall be dry, clean and free from moisture, dirt and loose foreign materials of any kind. All fittings shall be protected from rust, corrosion and mechanical damage during transportation, shipment and storage.
5. **Technical Specification for Copper Fittings:** This specification covers the requirements for Copper Capillary fittings (End feed). Unless modified by this specification requirement European EN 1254 Part-I shall be valid.
- 5.1. **MATERIAL:** The material used for the manufacturer of Copper Capillary Fittings shall conform to BS EN 1254 - 1: latest Half hard. Material used for the solder should conform to BS 219 & BS EN 29453 or equivalent and should be lead free.
- 5.2. **DIMENSIONAL TOLERANCES:** Dimensions tolerances of various types of copper capillary fittings (End feed) shall be as per BS 864 Part-2 (latest) & EN 1254 (Open tolerances on dimensions shall be +/-0.1 mm). The tolerances as specified in EN 1254 in nominal diameter are as follows (Ref Table 2).

Nominal Diameter	Tolerance on the mean diameter with respect to the nominal diameter		Resulting Difference	Diametrical
D	Outside Dia of male end (mm)	Inside Dia of Socket (mm)	Max. (mm)	Min. (mm)
12 mm	+ .0.04 – .0.05	+ 0.15 - 0.06	0.20	0.02

The minimum wall thickness of a fitting shall be in accordance as given below (Ref. Table 5 of EN 1254). Nominal Dia mm D: 12 - Minimum wall thickness (mm)Wrought Coppers 0.6

End connection of the Fitting must be capable of end feeding. Internal solder ring type fitting is not acceptable.

5.3. **CARBON IN BORE:** The internal surface of copper capillary fittings for soldering or brazing shall not contain any detrimental film nor present a carbon level high enough to allow the formation of such a film during installation. The maximum total carbon level on internal surfaces shall not exceed 1.0 mg/dm² when tested in accordance with the specification.

5.4. **CHEMICAL PROPERTIES:** Each heat no. of the copper fitting will be tested for chemical properties to conform to non-arsenical copper DHP grade C 106 as per BS EN 1057 &BS 2871 to have the following chemical composition:

Copper Percentage: Min 99.9%

Phosphorus Percentage : 0.015 to 0.040%

The fittings shall be free from internal fins, blow holes, skin defects etc. or other irregularities which might restrict the free flow of fluid, and shall be designed that resistance to the flow of fluid through the fittings is minimized.

5.5. **PRESSURE TEST:** All fittings shall be leak tested at the option of BGL at a pressure of 1 bar (g) for a period of 2 minutes and no leakage is permitted during this period Manufacturer's Test Certificate is necessary with supply.

5.6. **STRESS CORROSION RESISTANCE TEST:** A Stress Corrosion Resistance is to be carried out as per method defined in ISO 6957 using test solution of pH 9.5 but without pickling.

5.7. **MARKING:** Each tube shall be embossed with manufacturers name or trade mark BS 864 or EN 1254. Each packing containing fittings shall carry the following stamped or written in indelible ink.

- a) Manufacturer's name or trade mark
- b) Designation of tubes
- c) BS Symbol mentioning as 864 or EN 1254 to be used.

6. **Standard Specification for Brass Fittings:** This specification covers the requirements for Brass Fittings. The fittings should be suitable for use with normal working pressure of 100m bar & maximum working pressure of 200m bar. Unless modified by this specification, requirement of BS:746shall be valid. All pressure mentioned in this specification are Gauge Pressures.

6.1. **MATERIAL:** The material used for the manufacturer of Brass fittings shall confirm to IS:319 or EN 1254-1(latest). Free cutting extruded brass rod. Vendors shall use materials having valid BIS or BS monogram. Material used for the solder should

conform to BS EN 29453 and should be lead free. Solder material shall be generally melting within the temperature range 180 to 250 c Threading on the Brass Fitting shall be done by BS 21.

6.2. DIMENSIONAL TOLERANCES: Dimensions tolerances of various types of fittings shall be as per BS:746.

Diameter	Tolerance on mean Diameter w.r.t. the nominal diameter		Resulting Diametrical Difference	
	Outside Dia of male end	Inside dia of male end	Max (mm)	Min(mm)
12 mm	+0.04	+0.15	0.20	0.02
	-0.05	+0.06		

6.3. Union nuts shall be of hexagonal type. The Minimum wall thickness of a fitting shall be in accordance as given below.

6.4. THREADS: Fittings shall be threaded to dimensions & the tolerances as specified in BS:21 unless specified otherwise. Provisions for tightening shall be made on all straight fittings. All male & female threads are tapered. The outlet of the fittings shall have a chamfer the chamfer shall have an included angle of $90^{\circ} \pm 5^{\circ}$ for internal threads & $70^{\circ} \pm 10^{\circ}$ for external threads.

6.5. The fittings shall be free from internal fins or other irregularities which might restrict the free flow of fluid & shall be so designed that resistance to the flow of fluid through the fittings is minimized.

6.6. Carbon in Bore: The internal surface of brass capillary fittings for soldering or brazing shall not contain any detrimental film nor present a carbon level high enough to allow the formation of such a film during installation. The maximum total carbon level on internal surface shall not exceed 1.0 mg/dm² when tested in accordance with specification. Test shall have carried out as per EN 1254-1.

6.7. Resistance to Dezincification: The fitting shall be manufactured form alloys containing more than 10% Zinc. So, fittings shall be required to be resistant to dezincification it shall be carried as per EN -1254-1.

6.8. Stress Corrosion Resistance Test: A stress corrosion resistance is to be carried out as per method defined in ISO 6957 using test solution of pH 9.5 but without pickling.

6.9. PRESSURE TEST: All fittings shall be leak tested at a pressure of 1 bar (g) for a period of 5 minutes & no leakage is permitted during this period.

6.10. MARKING: Each fitting shall be embossed with manufacturers name or trade mark. Each packing containing fittings shall carry the following stamped or written in indelible ink.

- a) Manufacturer's name of trade mark
- b) Designation of fittings
- c) Lot number

7. **Technical Specification for Isolation & Appliance Ball Valves:** The intent of this specification is to establish minimum requirements to manufacture and supply of Isolation & Appliance Ball Valves used for supply of natural gas.

7.1. **Material specification for Isolation Valves:** Isolation Ball Valve with Full Bore, NPT Female (Confirming to ANSI B1.20.1) ends for natural gas application).

Sizes	½"
Body	Hot Pressed/ Forged Brass, Nickel/ Chrome Plated
Ball	Hard Chrome/ Nickel Plated Hot Pressed/ Machined Brass Bar with Teflon Seat. With operating Knob and locking arrangement with sealing wire and lead seal (Without Key). Valve full open/ close position shall be at 90°.
Maximum Operating Pressure	4.0 Bar (g)
Hydrostatic Test Pressure	6.0 Bar (g)
Markings	Manufacturer's name or trade mark Model designation. Rate working pressure in Bar & Direction of flow, if necessary
Leakage	The permissible external/ internal leakage shall be specified by the vendor, with reference to relevant code. However, in no case the leakage in both the cases shall exceed 1 ml/ min at maximum working pressure specified.
Mechanical Strength	The body of the valves shall be capable of withstanding without deformation or leakage 125 Nm torque, as applied to a pipe being connected to the valve. Valve shall be capable of withstanding without deformation or leakage 340 Nm bending moment or an angular displacement of 10° whichever occurs first, if applied to a pipe connected to the valve. The valves shall be capable of withstanding 25 Nm impact without breakage or leakage.

7.2. **Material specification for Appliance Valves:**

Application Ball Valve	Full Bore with ½" NPT (Confirming to ANSI B1.20.1) Female as an inlet and the outlet shall be having Ni/ Cr plated brass or steel a nozzle (Serrated to suit ¼" rubber tubing/ hose connection) and the material is required for Domestic Natural Gas Service.
Body	Total body including the nozzle shall be of Hot Pressed/ Forged Brass, Nickel/ Chrome Plated.
Ball	Hard Chrome/ Nickel Plated Hot Pressed/ Machined Brass Bar with Teflon Seat With a metallic operating/ knob/ lever for full open/ close at 90° position.
Maximum Operating Pressure	35 milli Bar (g)
Hydrostatic	1.0 Bar (g)

Test Pressure	
Markings	Manufacturer's name or trade mark, Model designation, Rate working pressure in Bar, Direction of flow, if necessary
Leakage	The permissible external/ internal leakage shall be specified by the vendor, with reference to relevant code. However, in no case the leakage in both the cases shall exceed 1 ml/ min at maximum working pressure specified.
Mechanical Strength	<p>The body of the valves shall be capable of withstanding without deformation or leakage 75 Nm torque, as applied to a pipe being connected to the valve.</p> <p>Valve shall be capable of withstanding without deformation or leakage 125 Nm bending moment or an angular displacement of 10° whichever occurs first, if applied to a pipe connected to the valve.</p> <p>The valves shall be capable of withstanding 25 Nm impact without breakage or leakage.</p>

PART III OF SCC

1. Labour

- 1.1. The Contractor shall make his own arrangements for the engagement of all Labour for doing the work at site or in respect of or in connection with the execution of work as also for the transport, housing, feeding and payment thereof.
- 1.2. The Contractor shall provide on the site, adequate supply of drinking and other water for the use of the Contractor's staff and Labour.
- 1.3. The Contractor shall not import, sell, give, barter or otherwise dispose of any alcoholic liquor, or drugs, or permit or any such importation, sale, gift, barter or disposal by his subcontractor/ s, his, agents or employees.
- 1.4. The Contractor shall not give, barter or otherwise dispose of to any person or persons, any arms or ammunition of any kind or permit the same as aforesaid by his sub- contractor/s, his/their servants, agents or employees.
- 1.5. The Contractor shall in all dealings with Labour in his employment have due regard to all recognized festivals, days of rest and religious or other customs.
- 1.6. In the event of any outbreak of illness of an epidemic nature, the Contractor shall comply with any carry out such regulations, orders and requirements as may be made by the Government, or the local medical or sanitary
- 1.7. The Contractor shall at all times take all reasonable precautions to prevent any unlawful, riots or disorderly conduct by or amongst his employees/Labour and for the preservation of peace and protection of persons and property in the neighborhood of the works against the same.
- 1.8. The Contractor shall pay the Labour engaged by him on the work not less than a fair wage, which expression shall mean, whether for time or piece work, rates of wages as may be fixed by the Department of Labour, Government of Goa as fair wages for North-Goa & Ponda Urban Region payable to the different categories of Labour or those notified under the Minimum Wages Act for corresponding employees of the GNGPL/Engineer-in-Charge whichever may be higher.
- 1.9. The Contractor shall notwithstanding the provisions of any contract to the contrary, cause to be paid a fair wage to the Labour indirectly engaged by Sub-Contractors in connection with the said works as if the Labour had been directly employed by him.
- 1.10. The Contractor shall maintain records of wages and other remuneration paid to his employees in such form as may be convenient and to the satisfaction of the

GNGPL/ Engineer-in-Charge and the Conciliation Officer (Central), Ministry of Labour, Government of India, or such other authorized person appointed by Central or State Government.

- 1.11. The GNGPL/ Engineer-in-Charge or any other person authorized by him on his behalf shall have power to make enquiries with a view to ascertaining and enforcing due and proper observance of the Fair Wages Clauses. The GNGPL/Engineer-in-Charge shall also have the power to investigate into any complaint regarding any default made by the Contractor or his sub-Contractor in regard to such provision.
- 1.12. The GNGPL/Engineer-in-Charge shall have the right to deduct from the moneys due to the Contractor any sum required or estimated to be required for making good the loss suffered by a worker or workers by reason of non-payment of fair wage, except any deductions that may be permissible under any law for the time being in force.
2. **Labour License:** Before starting of work at site, Contractor shall obtain a license from concerned authorities under the Contract Labour (Abolition and Regulation) Act 1970, and furnish copy of the same to GNGPL.
3. **Labour Relations**
 - 3.1. In case of Labour unrest/Labour dispute arising out of non-implementation of any law, the responsibility shall solely lie with the Contractor and he shall remove/resolve the same satisfactorily at his cost and risk.
 - 3.2. The Contractor shall at all times take all reasonable precautions to prevent any unlawful, riotous or disorderly conduct by or amongst his staff and Labour and to preserve peace and protection of persons and property in the neighbourhood of the Works against such conduct.
4. **Labour & Statutory Responsibilities of the Contractor:**
 - 4.1. The contractor shall have his own PF code no. with the RPFC as required under Employee PF & Miscellaneous Provisions Act, 1952 and extend benefits of Provident Fund, Employee Deposit Linked Insurance and Employee Pension Scheme 1995.
 - 4.2. The contractor shall have his own ESI code No. allotted by Employee State Insurance Corporation (ESIC) as required under Employee State Insurance Act 1948.
 - 4.3. The contractor shall submit the Electronic Challans cum Returns (ECR) along with bank receipts/ bank statement on monthly basis for the proof of depositing of PF contribution with Provident Fund Authorities and ESI contribution with ESI Authorities.

- 4.4. The contractor shall discharge obligations as provided under various statutory enactment including the employees Provident Fund and Miscellaneous Provisions Act, 1952, Contract Labour (R&A) Act, 1970, Minimum Wages Act, 1948, Payment of wages act 1936, Workman Compensation Act 1923, Employees' State Insurance Act 1948 and other relevant acts, rules and regulations enforced from time to time.
- 4.5. The contractor shall be solely responsible for the payment of wages and other dues to the personnel, if any, deployed by him latest by 7th day of the subsequent month in the presence of Engineer In-Charge. After disbursement of wages the authorized representative and Engineer-in-charge have to certify the payment of wages to the contract workers and sign the e-banking wage sheet/ bank statement jointly.
- 4.6. The contractor shall be solely responsible and indemnify the GNGPL against all charges, dues, claim etc. arising out of the disputes relating to the dues and employment of personnel, if any, deployed by him.
- 4.7. The contractor shall indemnify GNGPL against all losses or damages, if any, caused to it on account of acts of the personnel, if any, deployed by him.
- 4.8. All personnel deployed by the contractor should be on the rolls of the contractor.
- 4.9. No contract worker below the age of 18 years & above the age of 55 years shall be deployed on the work.
- 4.10. The personnel to be deputed by the contractor shall observe all security, fire and safety rules of GNGPL while at the Site/work. His Work/Services will be supervised by the supervisors of contractor. Contractor has to strictly adhere to the guidelines/instructions issued from time to time.
- 4.11. Contractor has to deploy the personnel with no past criminal records. Also the contractor has to provide police verification for all the persons deployed by him.
- 4.12. While confirming to any of these conditions, the contractor should ensure that no law of state regarding Labour, their welfare, conduct etc. is violated. The contractor shall indemnify GNGPL for any action brought against him for violation, non-compliance of any act, rules & regulation of center/ state/ local statutory authorities.
- 4.13. All existing and to be amended from time to time the safety/ fire rules of GNGPL are to be strictly adhered to.
- 4.14. In case of accident, injury and death caused to the employee of the contractor while executing the Work under the contract, the contractor shall be solely responsible for payment of adequate compensation, insurance money etc. to the next kith & kin of injured / diseased. Contractor shall indemnify GNGPL from all such liabilities.

- 4.15. The contractor shall not employ or permit to be employed any person suffering from any contagious, loathsome or infectious disease. The contractor shall get examined his employees/ persons deployed from a civil govt. doctor before engagement.
- 4.16. No employees or person of contractor (including contractor) be allowed to consume alcoholic drinks or any narcotics within the Gas Installations. If found under the influence of above, the GNGPL/ GNGPL will terminate the contract immediately and may refer the case to police.
- 4.17. The contractor hereby agrees to indemnify GNGPL and harmless from all claims, demands, actions, cost and charges etc. brought by any court, competent authority / statutory authorities against GNGPL.
- 4.18. The contractor is required to file Half Yearly Return in FORM XXIV before concerned ACL (Central), the Licensing Officer within 30 days from the end of Half Year.
- 4.19. The following documents shall be submitted by the Agency/contractor to the Engineer In- Charge at various stages during the currency of the contract:
- 4.20. After issuance/ receiving of Letter of Intent (FOA/LOI):
- 4.20.1. Application for issuance of Form -V or equivalent for obtaining Labour License from Licensing Authority for engaging 20 or more contract workers.
 - 4.20.2. Copy of Labour License before commencement of work if 20 or more contract workers are engaged.
 - 4.20.3. List of persons along with designation, Employee No., PF account, ESI card No., Insurance coverage No. etc.
 - 4.20.4. Copies of Appointment Letters to the persons to be engaged in GNGPL by the contractor.
 - 4.20.5. Copies of Employment/Identity Card issued by the contractor for the persons to be engaged in GNGPL
 - 4.20.6. Copy of Provident Fund Registration Certificate issued by concerned Regional Provident Fund Commissioner.
 - 4.20.7. Copy of FORM 5 or equivalent submitted by the contractor to Regional Provident Fund Commissioner in respect of contract workers who are eligible to become members of the fund for the first time along with copies of declaration in FORM 2 furnished by such contract workers.
 - 4.20.8. Copies of allotment of Provident Fund A/c No. and contribution cards of all the individual contract workers engaged by him.
 - 4.20.9. Copy of Employee State Insurance Registration Certificate issued by concerned ESIC (wherever applicable}.
 - 4.20.10. Copies of return in FORM 3 submitted by the contractor to the ESIC with respect to declaration by contract workers for enrolment with ESIC.

- 4.20.11. Copies of ESI identity/smart Card of persons to be engaged in GNGPL
- 4.20.12. In case ESI is not applicable, copy of insurance coverage/policy along with details of contract workers and sum assured in terms of Employees Compensation Act, 1923 and copy of renewal of policy from time to time.
- 4.21. Contract Labour (Regulation & Abolition), Act, 1970 & Payment of wages Act,1936: During the currency of the contract, the contractor has to maintain registers e.g.
 - 4.21.1. Muster Roll in FORM-XVIII
 - 4.21.2. Register of workmen in FORM-XIII
 - 4.21.3. Wage Register in FORM-XVII
 - 4.21.4. Register of Deductions in FORM-XX
 - 4.21.5. Register of Over time in FORM-XXIII
 - 4.21.6. Register of Fines in FORM-XVI
 - 4.21.7. Register of advances in FORM-XXII
 - 4.21.8. Issuance and maintenance of Wage Slip in FORM XIX.
 - 4.21.9. Issuance of valid Identity Card by the contractor IN FORM XIV.
- 4.22. Employee State Insurance Act,1948: During the currency of the contract, the contractor has to maintain registers e.g.:
 - 4.22.1. Register of employees in FORM-6
 - 4.22.2. Accident Book in FORM-I1
- 4.23. Provident Fund & Misc. Provisions Act, 1952
 - 4.23.1. Monthly return in FORM 5 for employees qualifying for membership of the PF fund.
 - 4.23.2. Contribution card in FORM 4
 - 4.23.3. Return of contribution card sent to the Commissioner on expiry of the Financial Year in
 - 4.23.4. FORM 6
 - 4.23.5. Consolidated annual contribution statement in FORM 6. Copy of same should also be given to the individual contract worker and EIC every year.
- 4.24. At the time of closure of contract the contractor has to submit Indemnity Bond of Rs.100/- duly notarized from Notary indemnifying GNGPL from all liabilities w.r.t. the persons engaged by the contractor regarding payment of wages, Provident Fund/ESI contributions, Insurance and other payments in Performa Indemnity Bond.

5. Site Facilities: The Contractor shall arrange for the following facilities at site, for workmen deployed/engaged by him/his sub-contractor, at its own cost.
 - 5.1. Arrangement for First Aid.
 - 5.2. Arrangement for clean & potable drinking water.
 - 5.3. Canteen services for tea & snacks to be provided, as per Act.
 - 5.4. Any other facility/utility as may be required under the Contract.
6. Make of Materials
 - 6.1. All equipment and materials to be supplied under this contract shall be from approved vendors as accepted by GNGPL.
 - 6.2. Where the makes of materials are not indicated in the Bidding Document, Contractor shall furnish details of proposed makes and supply the same after written approval of GNGPL. Proposed makes will be considered, provided sufficient information are furnished to the GNGPL to assess the makes proposed by the Contractor as equivalent and acceptable.

PENALTY AND DEDUCTIONS:

1. In case manpower is less than the mentioned manpower requirement in a shift in any of O&M base office will attract a penalty of Rs.2000/- per person in a shift and any subsequent instance shall attract a penalty of Rs. 5000/- per instance with a notice to contractor.
2. Contractor will be held responsible for any theft or pilferages, loss, other offences and should liaison with police regarding the investigation for any malpractice. The particular employee should be terminated from his services immediately and replacement should be provided within 48 Hours, failing to which attract penalty according to non-availability of man power clause.

RECOVERY

- 1) Cost of any damage / loss of the property of GNGPL by the contractor shall be recovered from the Bills / Security Deposit of the contractor & the decision of GNGPL in this regard shall be final, binding and conclusive.
- 2) If the contractor fails to provide safety gears to his personnel within 15 days from the date of start of work, GNGPL shall provide the same, the cost of which, including the overheads as decided by GNGPL, shall be recovered from the contractor's Bills.

If at any moment GNGPL feels that the services provided is not satisfactory GNGPL reserves the right to De-hire the services immediately and in that case the Contractor will not be paid any Compensation and his Performance Bank Gaurantee (PBG) will be forfeited.

SECTION-IV

General Conditions of Contract (GCC)

GCC:

GENERAL CONDITIONS OF CONTRACT (GCC) IS AVAILABLE AT OFFICE OF GNGPL AND ON WEBSITE ALSO. GCC SHALL BE PART OF THIS TENDER. BIDDER SHALL READ, UNDERSTAND AND ACCEPT THE TERMS AND CONDITIONS OF GCC BEFORE SUBMITTING THE BID. ANY BIDDER WHO HAS SUBMITTED THE BID SHALL BE DEEMED THAT HE/HER/COMPANY HAS READ, UNDERSTOOD AND ACCEPTED THE TERMS AND CONDITIONS OF GCC.

SECTION-V
FORMS & FORMAT

FORMS & FORMAT

LIST OF FORMS & FORMAT WITH ITS APPLICABILITY FOR THIS TENDER

Form No.	Description	Applicability for this tender (Yes/No)
F-1	<u>BIDDER'S GENERAL INFORMATION</u>	YES
F-2	<u>BID FORM</u>	YES
F-3	LIST OF ENCLOSURES	YES
F-4	PROFORMA OF "BANK GUARANTEE" FOR "EARNEST MONEY / BID SECURITY"	YES
F-4A	PROFORMA OF "LETTER OF CREDIT" FOR "EARNEST MONEY / BID SECURITY"	YES
F-5	LETTER OF AUTHORITY	YES
F-6	NO DEVIATION CONFIRMATION	YES
F-7	DECLARATION REGARDING HOLIDAY/BANNING AND LIQUIDATION, COURT RECEIVERSHIP ETC.	YES
F-8	CERTIFICATE FOR NON-INVOLVMENT OF GOVT. OF INDIA	YES
F-9	PROFORMA OF "BANKGUARANTEE"FOR "CONTRACT PERFORMANCE SECURITY / SECURITY DEPOSIT"	YES
F-10	AGREED TERMS & CONDITIONS	YES
F-11	ACKNOWLEDGEMENT CUM CONSENT LETTER	YES
F-12	UNDERTAKING ON LETTERHEAD	YES
F-13	BIDDER'S EXPERIENCE	YES
F-14	CHECK LIST	YES
F-15	FORMAT FOR CERTIFICATE FROM BANK IF BIDDER'S WORKING CAPITAL IS INADEQUATE	YES
F-16	FORMAT FOR CHARTERED ACCOUNTANT CERTIFICATE FOR FINANCIAL CAPABILITY OF THE BIDDER	YES
F-17	FORMAT FOR CONSORTIUM/JV AGREEMENT	NO
F-18	BIDDER'S QUERIES FOR PRE-BID MEETING	YES
F-19	INDEMNITY BOND	YES
F-20	PROFORMA FOR CONTRACT AGREEMENT	YES
F-21	INTEGRITY PACT WITH ANNEXURE-1 & ANNEXURE- 2	YES

F-1
BIDDER'S GENERAL INFORMATION

To,
M/s. Goa Natural Gas Pvt. Ltd. (GNGPL),
Porvorim,
North Goa- 403 521.

TENDER NO:

1	Bidder Name	
2	Status of Firm	Proprietorship Firm/Partnership firm/ Limited/Others If Others Specify: _____ [Enclose certificate of Registration]
3	Name of Proprietor/Partners/Directors of the firm/company	
4	Number of Years in Operation	
5	Address of Registered Office: *In case of Partnership firm, enclose letter mentioning current address of the firm and the full names and current addresses of all the partners of the firm.	 City: District: State: PIN/ZIP:
6	Operation Address (if different from above)	 City: District: State: PIN/ZIP:
7	Telephone Number	_____ (Country Code) (Area Code) (Telephone No.)
8	E-mail address	
9	Website	
10	Fax Number:	_____ (Country Code) (Area Code) (Telephone No.)

11	ISO Certification, if any	{If yes, please furnish details}
12	Bid Currency	
13	Banker's Name	
14	Branch	
15	Bank account number	
16	PAN No.	[Enclose copy of PAN Card]
17	GST No.	[Enclose copy of GST Registration Certificate]
18	EPF Registration No.	[Enclose copy of EPF Registration Certificate]
19	ESI code No.	[Enclose copy of relevant document]
20	We (Bidder) are cover under the definition of section 2 (n) of the MSMED Act	Yes / No <i>(If the response to the above is 'Yes", Bidder to provide Purchaser a copy of the Entrepreneurs Memorandum (EM) filled with the authority specified by the respective State Government.)</i>
21	Whether Micro/Small/Medium Enterprise	Yes/No <i>(Bidder to submit documents as specified it ITB)</i>
22	Type of Entity	Corporate/ Non-Corporate (As per GST Act). <i>(In case of Non-Corporate Entity, bidder will submit documentary evidence for same).</i>

Place:

[Signature of Authorized Signatory of Bidder]

Date:

Name:

Designation:

Seal:

F-2
BID FORM

To,
M/s. Goa Natural Gas Pvt. Ltd. (GNGPL),
Porvorim,
North Goa- 403 521.

SUB:
TENDER NO:

Dear Sir,
After examining / reviewing the Bidding Documents for the tender of
"_____ including
"Specifications & Scope of Work", "General Conditions of Contract [GCC]", "Special Conditions
of Contract [SCC]" and "Schedule of Rates [SOR]", etc. the receipt of which is hereby duly
acknowledged, we, the undersigned, are pleased to offer to execute the whole part of the job
and in conformity with the said Bid Documents, including Addenda / Corrigenda Nos.
_____, if any.

We confirm that this Bid is valid for a period of "three [03] months" from the date of opening of
"Techno-Commercial / Un-priced Bid", and it shall remain binding upon us and may be
accepted by any time before the expiry of that period.

If our Bid is accepted, we will provide the "Contract Performance Security / Security Deposit"
equal to "_____ of the Contract Price" or as mentioned in Tender Document for the due
performance within "thirty [30] days" of such Award, if applicable.

Until a final Agreement/Letter of Award is prepared and executed, the tender document
(including addenda/ corrigenda) together with the "Notification of Award" shall constitute a
binding Agreement between us.

We understand that Bidding Document is not exhaustive and any action and activity not
mentioned in Bidding Documents but may be inferred to be included to meet the intend of the
Bidding Documents shall be deemed to be mentioned in Bidding Documents unless otherwise
specifically excluded and we confirm to perform for fulfillment of Agreement and completeness
of the Work in all respects within the time frame and agreed price.

We understand that you are not bound to accept the lowest priced or any Bid that you may
receive.

Place: [Signature of Authorized Signatory of Bidder]
Date: Name:
Designation:
Seal:

Duly authorized to sign Bid for and on behalf of _____

[Signature of Witness]
Name of Witness:
Address:

F-3

LIST OF ENCLOSURES

To,
M/s. Goa Natural Gas Pvt. Ltd. (GNGPL),
Porvorim,
North Goa- 403 521.

SUB:
TENDER NO:

Dear Sir,

We are enclosing the following documents as part of the bid:

1.
2.
3.
4.
5.
6.

Note:

* In case of e-bidding the bidder has the option to submit specified documents in physical form on/before the bid due date or within seven days from the bid opening date. However, scanned copy of these (same) documents must be submitted on-line as part of e-bid before the bid due date/time.

Place:
Date:

[Signature of Authorized Signatory of Bidder]
Name:
Designation:
Seal:

F-4

FORMAT FOR PROFORMA OF "BANK GUARANTEE" FOR "EARNEST MONEY / BID SECURITY" (To be stamped in accordance with the Stamp Act)

Ref

Date

Bank Guarantee No

To,

M/s Goa Natural Gas Pvt. Ltd.
Rajan Villa,
Plot-33,
Porvorim, Goa-403521

SUB:
TENDER NO:

Dear Sir(s),

In accordance with Letter Inviting Tender under your reference No _____ M/s.

_____ having their Registered / Head Office at _____ (hereinafter called the Tenderer), wish to participate in the said tender for

As an irrevocable Bank Guarantee against Earnest Money for the amount of _____ is required to be submitted by the Tenderer as a condition precedent for participation in the said tender which amount is liable to be forfeited on the happening of any contingencies mentioned in the Tender Document.

We, _____ the _____ having _____ our _____ Head Office at _____ (Local Address)

guarantee and undertake to pay immediately on demand without any recourse to the tenderers by GNGPL Ltd., the amount _____ without any reservation, protest, demur and recourse. Any such demand made by GNGPL, shall be conclusive and binding on us irrespective of any dispute or difference raised by the Tenderer.

This guarantee shall be irrevocable and shall remain valid up to _____ [this date should be two (02) months beyond the validity of the bid]. If any further extension of this guarantee is required, the same shall be extended to such required period on receiving instructions from M/s. _____ whose behalf this guarantee is issued.

In witness whereof the Bank, through its authorized officer, has set its hand and stamp on this _____ day of _____ 20__ at _____.

WITNESS:

(SIGNATURE)
(NAME)

(SIGNATURE)
(NAME)
Designation with Bank Stamp

(OFFICIAL ADDRESS)

Attorney as per
Power of Attorney No. _____
Date: _____

INSTRUCTIONS FOR FURNISHING "BID SECURITY / EARNEST MONEY" BY "BANK GUARANTEE"

1. The Bank Guarantee by Bidders will be given on non-judicial stamp paper as per "Stamp Duty" applicable. The non-judicial stamp paper should be in the name of the issuing Bank. In case of foreign Bank, the said Bank's Guarantee to be issued by its correspondent Bank in India on requisite non-judicial stamp paper
2. The expiry date should be arrived at in accordance with "ITB: Clause-15.1".
3. The Bank Guarantee by bidders will be given from Bank as specified in "ITB".
4. A letter from the issuing Bank of the requisite Bank Guarantee confirming that said Bank Guarantee / all future communication relating to the Bank Guarantee shall be forwarded to the Employer at its address as mentioned at "ITB".
5. Bidders must indicate the full postal address of the Bank along with the Bank's E-mail / Fax / Phone from where the Earnest Money Bond has been issued.
6. If a Bank Guarantee is issued by a commercial Bank, then a letter to Employer confirming its net worth is more than Rs. 1,000,000,000.00 [Rupees One Hundred Crores] or equivalent alongwith documentary evidence.

F-4A
PROFORMA OF "LETTER OF CREDIT" FOR "EARNEST MONEY / BID SECURITY"

To,
M/s. Goa Natural Gas Pvt. Ltd. (GNGPL),
Porvorim, North Goa- 403 521.

SUB:
TENDER NO:

Irrevocable and confirmed Letter of Credit No. Amount: Rs.

Validity of this Irrevocable: (in India)
Letter of Credit (2 months beyond validity of Offer)

Dear Sir,

1. You are hereby authorized to draw on (Name of Applicant with full address) for a sum not exceeding available by your demand letter (draft) on them at sight drawn for Rs.....accompanied by a certificate by GNGPL, with the Tender No. duly incorporated therein, that one or more of the following conditions has/have occurred, specifying the occurred condition(s):

- (i) The Bidder withdraws its Bid during the period of Bid validity or any extension thereof duly agreed by the Bidder.
 - (ii) The Bidder varies or modifies its Bid in a manner not acceptable to GNGPL during the period of bid validity or any extension thereof duly agreed by the Bidder.
 - (iii) The Bidder, having been notified of the acceptance of its Bids,
 - (a) Fails or refuses to execute the Supply Order/Contract
 - (b) Fails or refuses to furnish the Contract Performance Security within 30 days before expiry of Bid Security.
 - (c) Fails to accept arithmetic corrections as per tender conditions.
2. This Irrevocable Letter of Credit has been established towards Bid Security Tender No for..... (Item)
3. We hereby guarantee to protect the Drawers, Endorsers and bonafide holders from any consequences, which may arise in the event of the non-acceptance or non-payment of Demand Letter (draft) in accordance with the terms of this credit.
4. This Credit is issued subject to the Uniform Customs and Practices for Documentary Credits (1993 Revised) International Chamber of Commerce brochure No. 500.
5. Please obtain reimbursement as under:
6. All foreign as well as Indian bank charges will be on the account of M/s. (Applicant)

FOR
.....

Authorized Signature
(Original Bank)

Counter Signature

F-5

LETTER OF AUTHORITY

[Pro forma for Letter of Authority for Attending Subsequent 'Negotiations' / 'Pre-Bid Meetings' / 'Un-priced Bid Opening' / 'Price Bid Opening']

Ref:

Date:

To,

**M/s. Goa Natural Gas Pvt. Ltd. (GNGPL),
Porvorim,
North Goa- 403 521.**

SUB:

TENDER NO:

Dear Sir,

I/We, _____ hereby authorize the following representative(s) for attending any 'Negotiations' / 'Meetings [Pre-Bid Meeting]', 'Un-priced Bid Opening', 'Price Bid Opening' and for any subsequent correspondence / communication against the above Bidding Documents:

[1] Name & Designation _____ Signature _____
Phone/Cell: _____
Fax: _____
E-mail: @

[2] Name & Designation _____ Signature _____
Phone/Cell: _____
Fax: _____
E-mail: @

We confirm that we shall be bound by all commitments made by aforementioned authorized representative(s).

Place: _____

Date: _____

[Signature of Authorized Signatory of Bidder]

Name: _____

Designation: _____

Seal: _____

Note: This "Letter of Authority" should be on the "**letterhead**" of the Firm / Bidder and should be signed by a person competent and having the 'Power of Attorney' to bind the Bidder. Not more than 'two [02] persons per Bidder' are permitted to attend "Techno-commercial / Un-priced" & "Price Bid" Openings. Bidders authorized representative is required to carry a copy of this authority letter while attending the un-priced and priced bid opening, the same shall be submitted to GNGPL.

F-6
"NO DEVIATION" CONFIRMATION

To,
M/s. Goa Natural Gas Pvt. Ltd. (GNGPL),
Porvorim,
North Goa- 403 521.

SUB:
TENDER NO:

Dear Sir,

We understand that any 'deviation / exception' in any form may result in rejection of Bid. We, therefore, certify that we have not taken any 'exception / deviation' anywhere in the Bid and we agree that if any 'deviation / exception' is mentioned or noticed, our Bid may be rejected.

Place:	[Signature of Authorized Signatory of Bidder]
Date:	Name:
	Designation:
	Seal:

F-7
DECLARATION REGARDING HOLIDAY/BANNING AND LIQUIDATION, COURT RECEIVERSHIP

To,
M/s. Goa Natural Gas Pvt. Ltd. (GNGPL),
Porvorim,
North Goa- 403 521.

SUB:
TENDER NO:

Dear Sir,

We hereby confirm that we are not on 'Holiday' by GNGPL / GNGPL or Public Sector Project Management Consultant (like EIL, MECON only due to "poor performance" or "corrupt and fraudulent practices") or banned by Government department/ Public Sector on due date of submission of bid.

Further, we confirm that neither we nor our allied agency/(ies) (as defined in the Procedure for Action in case of Corrupt/ Fraudulent/ Collusive/ Coercive Practices) are on banning list of GNGPL or the Ministry of Petroleum and Natural Gas.

We also confirm that we are not under any liquidation, court receivership or similar proceedings or 'bankruptcy'.

In case it comes to the notice of GNGPL that the bidder has given wrong declaration in this regard, the same shall be dealt as 'fraudulent practices' and action shall be initiated as per the Procedure for action in case of Corrupt/Fraudulent/Collusive/Coercive Practices.

Further, we also confirm that in case there is any change in status of the declaration prior to award of contract, the same will be promptly informed to GNGPL by us.

Place: [Signature of Authorized Signatory of Bidder]
Date: Name:
Designation:
Seal:

F-8
CERTIFICATE FOR NON-INVOLVMENT OF GOVT. OF INDIA

To,
M/s. Goa Natural Gas Pvt. Ltd. (GNGPL),
Porvorim,
North Goa- 403 521.

SUB:
TENDER NO:

Dear Sir,

If we become a successful Bidder and pursuant to the provisions of the Bidding Documents, award is given to us for the tender for “
_____”, the following Certificate shall be automatically enforceable:

"We agree and acknowledge that the Employer is entering into the Agreement solely on its own behalf and not on behalf of any other person or entity. In particular, it is expressly understood & agreed that the Government of India is not a party to the Agreement and has no liabilities, obligations or rights thereunder. It is expressly understood and agreed that the Employer is authorized to enter into Agreement, solely on its own behalf under the applicable laws of India. We expressly agree, acknowledge and understand that the Employer is not an agent, representative or delegate of the Government of India. It is further understood and agreed that the Government of India is not and shall not be liable for any acts, omissions, commissions, breaches or other wrongs arising out of the Agreement. Accordingly, we hereby expressly waive, release and forego any and all actions or claims, including cross claims, VIP claims or counter claims against the Government of India arising out of the Agreement and covenants not to sue to Government of India as to any manner, claim, cause of action or things whatsoever arising of or under the Agreement."

Place: [Signature of Authorized Signatory of Bidder]
Date: Name:
Designation:
Seal:

PROFORMA OF "BANK GUARANTEE" FOR "CONTRACT PERFORMANCE SECURITY / SECURITY DEPOSIT"

(ON NON-JUDICIAL STAMP PAPER OF APPROPRIATE VALUE)

To,
M/s GNGPL

PERFORMANCE GUARANTEE No.

Dear Sir(s),

M/s. _____
having registered office at _____ (herein after called the "contractor"
which expression shall wherever the context so require include its successors and
assignees) have been awarded the work of
_____ vide LOA /FOA No.

_____ dated _____ for GNGPL, 3rd floor, M S Complex,
S-44, New BEL Road, North Goa-560054.

The Contract conditions provide that the CONTRACTOR shall pay a sum of Rs.
_____ (Rupees _____)
as full Contract Performance Guarantee in the form therein mentioned. The form of payment of
Contract Performance Guarantee includes guarantee executed by Nationalized Bank,
undertaking full responsibility to indemnify GNGPL, in case of default.

The said _____ has approached us
and at their request and in consideration of the premises we having our office at
_____ have agreed to give such guarantee as hereinafter
mentioned.

1. We

_____ hereby undertake to give the irrevocable & unconditional guarantee to you that if
default shall be made by M/s. _____ in performing
any of the terms and conditions of the tender or in payment of any money payable to
GNGPL we shall on first demand pay without demur, contest, protest and/ or without
any recourse to the contractor to you in such manner as you may direct the said amount
of Rupees _____ only or such portion thereof not
exceeding the said sum as you may require from time to time.

2. You will have the full liberty without reference to us and without affecting this guarantee,
postpone for any time or from time to time the exercise of any of the powers and rights
conferred on you under the contract with the said

_____ and to enforce or to forbear from endorsing any powers or rights or by reason of time being given to the said _____ and such postponement forbearance would not have the effect of releasing the bank from its obligation under this debt.

3. Your right to recover the said sum of Rs. _____ (Rupees _____) from us in manner aforesaid will not be affected or suspended by reason of the fact that any dispute or disputes have been raised by the said M/s. _____ and/or that any dispute or disputes are pending before any officer, tribunal or court and any demand made by you in the bank shall be conclusive and binding. The bank shall not be released of its obligations under these presents by any exercise by you of its liberty with reference to matter aforesaid or any of their or by reason or any other act of omission our commission on your part or any other indulgence shown by you or by any other matter or changed what so ever which under law would, but for this provision, have the effect of releasing the bank.
4. The guarantee herein contained shall not be determined or affected by the liquidation or winding up dissolution or changes of constitution or insolvency of the said contractor but shall in all respects and for all purposes be binding and operative until payment of all money due to you in respect of such liabilities is paid.
5. This guarantee shall be irrevocable and shall remain valid upto _____ (this date should be 90 days after the expiry of defect liability period) _____. The bank undertakes not to revoke this guarantee during its currency without your previous consent and further agrees that the guarantee. However, if for any reason, the contractor is unable to complete the work within the period stipulated in the contract and in case of extension of the date of completion resulting extension of defect liability period of the contractor fails to perform the work fully, the bank hereby agrees to further extend this guarantee at the instance of the contractor till such time as may be determined by the owner. If any further extension of this guarantee is required, the same shall be extended to such required period on receiving instruction from M/s. _____ (contractor) on whose behalf this guarantee is issued.
6. The Bank Guarantee's payment of an amount is payable on demand and in any case within 48 hours of the presentation of the letter of invocation of Bank Guarantee. Should the banker fail to release payment on demand, a penal interest of 18% per annum shall become payable immediately and any dispute arising out of or in relation to the said Bank Guarantee shall be subject to the jurisdiction of Delhi Courts.
7. Therefore, we hereby affirm that we are guarantors and responsible to you on behalf of the Contractor up to a total amount of _____ (amount of guarantees in words and figures) and we undertake to pay you, upon your first written demand declaring the Contractor to be in default under the contract and without caveat or

argument, any sum or sums within the limits of (amounts of guarantee) as aforesaid, without your needing to prove or show grounds or reasons for your demand or the sum specified therein.

8. We have power to issue this guarantee in your favor under Memorandum and Articles of Association and the undersigned has full power to do under the Power of Attorney, dated _____ granted to him by the Bank.

Yours faithfully,

Bank by its Constituted Attorney

Signature of a person duly
Authorized to sign on behalf of the
Bank

INSTRUCTIONS FOR FURNISHING
"CONTRACT PERFORMANCE SECURITY / SECURITY DEPOSIT" BY "BANK
GUARANTEE"

1. The Bank Guarantee by successful Bidder(s) will be given on non-judicial stamp paper as per 'stamp duty' applicable. The non-judicial stamp paper should be in name of the issuing bank. In case of foreign bank, the said Bank Guarantee to be issued by its correspondent bank in India on requisite non-judicial stamp paper and place of Bid to be considered as Delhi.
2. The Bank Guarantee by Bidders will be given from bank as specified in Tender.
3. A letter from the issuing bank of the requisite Bank Guarantee confirming that said Bank Guarantee and all future communication relating to the Bank Guarantee shall be forwarded to Employer.
4. If a Bank Guarantee is issued by a commercial bank, then a letter to Employer and copy to Consultant (if applicable) confirming its net worth is more than Rs. 100,00,00,000.00 [Rupees One Hundred Crores] or its equivalent in foreign currency alongwith documentary evidence.

F-10
AGREED TERMS & CONDITIONS

To,
M/s. Goa Natural Gas Pvt. Ltd. (GNGPL),
Porvorim,
North Goa- 403 521.

SUB:
TENDER NO:

This Questionnaire duly filled in, signed & stamped must form part of Bidder's Bid and should be returned along with Un-priced Bid. Clauses confirmed hereunder need not be repeated in the Bid.

SI.	DESCRIPTION	BIDDER'S CONFIRMATION
1	Bidder's name and address	
2.	Please confirm the currency of quoted prices is in Indian Rupees.	
3.	Confirm quoted prices will remain firm and fixed till complete execution of the order.	
4	Rate of applicable GST%
5.	Confirm acceptance of relevant Terms of Payment specified in the Bid Document. In case of delay, the bills shall be submitted after deducting the price reduction due to delay.	
6.	Confirm that Contract Performance Bank Guarantee will be furnished as per Bid Document.	
7.	Confirm that Contract Performance Bank Guarantee shall be from any Indian scheduled bank or a branch of an International bank situated in India and registered with Reserve bank of India as scheduled foreign bank. However, in case of bank guarantees from banks other than the Nationalised Indian banks, the bank must be a commercial bank having net worth in excess of Rs 100 crores and a declaration to this effect shall be made by such commercial bank either in the Bank Guarantee itself or separately on its letterhead.	
8.	Confirm compliance to Completion Schedule as specified in Bid document. Confirm contract period shall be reckoned from the date of Fax of Acceptance.	
9.	Confirm acceptance of Price Reduction Schedule for delay in completion schedule specified in Bid document.	
10.	Confirm acceptance of all terms and conditions of Bid Document (all sections).	
11.	Confirm your offer is valid for 3 MONTHS from Final/Extended due date of opening of Techno-commercial Bids.	

SI.	DESCRIPTION	BIDDER'S CONFIRMATION
12.	Please furnish EMD/Bid Security details: EMD/ Bid Security No. & date Value Validity	
13.	Confirm acceptance to all provisions of ITB read in conjunction with Bid Data Sheet (BDS).	
13.	Confirm that Annual Reports for the last three financial years are furnished alongwith the Un-priced Bid.	
14.	Confirm that, in case of contradiction between the confirmations provided in this format and terms & conditions mentioned elsewhere in the offer, the confirmations given in this format shall prevail.	
15.	Confirm the none of Directors of bidder is a relative of any Director of Owner or the bidder is a firm in which any Director of Owner/ GNGPL or his relative is a partner.	
17.	All correspondence must be in ENGLISH language only.	
18	Owner reserves the right to make any change in the terms & conditions of the TENDER/BIDDING DOCUMENT and to reject any or all bids.	
19	Confirm that all Bank charges associated with Bidder's Bank shall be borne by Bidder.	

Place:
Date:

[Signature of Authorized Signatory of Bidder]
Name:
Designation:
Seal:

F-11
ACKNOWLEDGEMENT CUM CONSENT LETTER

(On receipt of tender document/information regarding the tender, Bidder shall acknowledge the receipt and confirm his intention to bid or reason for non-participation against the enquiry /tender through e-mail/fax to concerned executive in GNGPL issued the tender, by filling up the Format)

To,

M/s GNGPL

SUB:

TENDER NO:

Dear Sir,

We hereby acknowledge receipt of a complete set of bidding document along with enclosures for subject item/job and/or the information regarding the subject tender.

- We intend to bid as requested for the subject item/job and furnish following details with respect to our quoting office:

Postal Address with Pin Code :

Telephone Number :

Fax Number :

Contact Person :

E-mail Address :

Mobile No. :

Date :

Seal/Stamp :

- We are unable to bid for the reason given below:

Reasons for non-submission of bid:

Agency's Name :

Signature :

Name :

Designation :

Date :

Seal/Stamp :

F-12
UNDERTAKING ON LETTERHEAD

To,
M/s. Goa Natural Gas Pvt. Ltd. (GNGPL),
Porvorim,
North Goa- 403 521.

SUB:
TENDER NO:

Dear Sir

We hereby confirm that "The contents of this Tender Document No. _____
have not been modified or altered by M/s.
..... (Name of the bidder
with complete address). In case, it is found that the tender document has been modified /
altered by the bidder, the bid submitted by
M/s.....(Name of the bidder) shall be liable for
rejection".

Place: [Signature of Authorized Signatory of Bidder]
Date: Name:
Designation:

F-14
CHECK LIST

Bidders are requested to duly fill in the checklist. This checklist gives only certain important items to facilitate the bidder to make sure that the necessary data/information as called for in the bid document has been submitted by them along with their offer. This, however, does not relieve the bidder of his responsibilities to make sure that his offer is otherwise complete in all respects. Please ensure compliance and tick (√) against following points:

S. No.	DESCRIPTION	CHECK BOX
1.0	Confirm that the following details have been submitted in the Un-priced part of the bid	
I.	Covering Letter, Letter of Submission	
II.	Bid Security	
III.	Signed and stamped original copy of bidding document along with drawings and addendum (if any)	
IV.	Power of Attorney in the name of person signing the bid.	
V.	Copies of documents defining constitution or legal status, place of registration and principal place of business of the company	
VI.	Bidders' declaration that regarding, Holiday/ Banning, liquidation court receivership or similar proceedings	
VII.	Details and documentary proof required against BEC/qualification criteria along with complete documents establishing ownership of equipment as per SCC are enclosed	
VIII.	Confirm submission of document along with techno-commercial bid as per bid requirement.	
IX.	Confirm that all applicable forms duly filled in are enclosed with the bid duly signed by authorized person(s)	
X.	Integrity Pact duly filled, signed and stamped	
2.0	Confirm that the price part as per Price Schedule/SOR format submitted with Bidding Document/ uploaded in case of e-bid in separate envelope with title "Price Bid".	

Place:
Date:

[Signature of Authorized Signatory of Bidder]
Name:
Designation:
Seal:

F-15
FORMAT FOR CERTIFICATE FROM BANK
IF BIDDER'S WORKING CAPITAL IS INADEQUATE
(To be provided on Bank's letter head)

Date:

To,
M/s. Goa Natural Gas Pvt. Ltd. (GNGPL),
Porvorim,
North Goa- 403 521.

Dear Sir,

This is to certify that M/s (name of the bidder with address)
(hereinafter referred to as Customer) is an existing customer of our Bank.

The Customer has informed that they wish to bid for GNGPL's RFQ/Tender no.
..... dated for(Name
of the supply/work/services/consultancy) and as per the terms of the said RFQ/Tender they
have to furnish a certificate from their Bank confirming the availability of line of credit.

Accordingly M/s (name of the Bank with address) confirms availability
of line of credit to M/s (name of the bidder) for at least an amount of Rs.

It is also confirmed that the net worth of the Bank is more than Rs. 100 Crores (or Equivalent
USD) and the undersigned is authorized to issue this certificate.

Yours truly

for (Name & address of Bank)

(Authorized
signatory) Name of :
the signatory :
Designation Stamp

F-16
FORMAT FOR CHARTERED ACCOUNTANT CERTIFICATE FOR FINANCIAL CAPABILITY OF THE BIDDER

We have verified the Annual Accounts and other relevant records of M/s..... (Name of the bidder) and certify the following

ANNUAL TURNOVER OF LAST 3 YEARS:

Year	Amount (Currency)
Year 1:	
Year 2:	
Year 3:	

FINANCIAL DATA FOR LAST AUDITED FINANCIAL YEAR:

Description	Year _____
	Amount (Currency)
1. Current Assets	
2. Current Liabilities	
3. Working Capital (Current Assets- Current liabilities)	
4. Net Worth (Paid up share capital and Free Reserves & Surplus)	

Name of Audit Firm:
Chartered Accountant
Date:

[Signature of Authorized Signatory]
Name:
Designation:
Seal:
Membership no.

Instructions:

The financial year would be the same as one normally followed by the bidder for its Annual Report.

The bidder shall provide the audited annual financial statements as required for this Tender document.

Failure to do so would result in the Proposal being considered as non-responsive.

For the purpose of this Tender document, (i) Annual Turnover shall be "Sale value/ Operating Income"

(ii) Working Capital shall be "Current Assets less Current liabilities" and (iii) Net Worth shall be "Paid up share capital and Free Reserves & Surplus"

This certificate is to be submitted on the letter head of Chartered Accountant.

F-18
BIDDER'S QUERIES FOR PRE-BID MEETING

To,
M/s. Goa Natural Gas Pvt. Ltd. (GNGPL),
Porvorim,
North Goa- 403 521.

Sub :
Tender No :

SL	REFERENCE OF BIDDING DOCUMENT				BIDDER'S QUERY	GNGPL'S REPLY
	Sec No.	Page No.	Clause No.	Subject		

NOTE: The Pre-Bid Queries may be sent by fax and/or also by e-mail before due date for receipt of Bidder's queries.

SIGNATURE OF BIDDER: _____
NAME OF BIDDER: _____

F-19

(PROFORMA FOR INDEMNITY BOND)

INDEMNITY BOND

WHEREAS **Goa Natural Gas Private Limited** (Hereinafter referred to as GNGPL) which expression shall, unless repugnant to the context include their legal representatives, successors and assigns, having their Registered Office at 33, Rajan Villa, Near Journalist Colony, Porvorim, Goa has entered into a CONTRACT with

_____ **“(name of Agency)”** hereinafter referred to as the (‘AGENCY’) which expression shall unless repugnant to the context include their legal representatives, successors and assigns, having their Registered Officer at _____ for Rs. _____
_____ (contract value) for

_____ **(“NAME OF THE WORK”)** for a period of
“_____” and on the terms and conditions as set out, inter-alia in the Work Order No. _____ and various documents forming part thereof hereinafter collectively referred to as the ‘CONTRACT’ which expression shall include all amendments, modifications and / or variations thereto.

GNGPL has also advised the AGENCY to execute an Indemnity Bond in favour of GNGPL indemnifying it from all consequences which may arise out of any Case filed by any workers / Labourers / vendors / sub-contractors / partner etc who may have been engaged by the AGENCY directly or indirectly with or without consent of GNGPL for above works, which may be pending before any court of Law including Quasi-Judicial Authority, Competent Authority, Labour Court, Arbitrator, Tribunal etc.

NOW, THEREFORE, in consideration of the promises aforesaid; the AGENCY hereby irrevocably and unconditionally undertakes to indemnify and keep indemnified GNGPL from any loss, which may arise out of any such contract/Case. The AGENCY undertake to compensate to GNGPL forthwith, on demand, without protest the loss suffered by GNGPL together direct / indirect expenses.

AND THE AGENCY hereby agrees with GNGPL that:

- (i) This Indemnity Bond shall remain valid and irrevocable for all claims of GNGPL arising from any such contract/case for which GNGPL has been made party until now here-in-after.

- (ii) This Indemnity Bond shall not be discharged/revoked by any change / modification / amendment / deletion in the constitution of the firm / Agency or any conditions thereof including insolvency etc. of the AGENCY but shall be in all respects and for all purposes binding and operative until any claim for payment are settled by the Agency.

The under signed has full power to execute this Indemnity Bond on behalf of the AGENCY and the same stands valid.

[SIGNATURE OF AUTHORIZED REPRESENTATIVE]

Place:

Name:

Date:

Designation:

Seal:

PROFORMA FOR CONTRACT AGREEMENT

LOA/WORK ORDER NO.

DATE -----

Contract Agreement for the work of _____

_____ of GOA NATURAL GAS

PRIVATE LIMITED made on _____ between (Name and Address)

hereinafter called the "CONTRACTOR" (which term shall unless excluded by or repugnant to the subject or context include its successors and permitted assignees) of the one part and GOA NATURAL GAS PRIVATE LIMITED hereinafter called the "EMPLOYER" (which term shall, unless excluded by or repugnant to the subject or context include its successors and assignees) of the other part.

WHEREAS

A. The EMPLOYER being desirous of having provided and executed certain work mentioned, enumerated or referred to in the Tender Documents including Letter Inviting Tender, General Tender Notice, General Conditions of Contract, Special Conditions of Contract, Specifications, Drawings, Plans, Time Schedule of completion of jobs, Schedule of Rates, Agreed Variations, other documents has called for Tender.

B. The CONTRACTOR has inspected the SITE and surroundings of WORK specified in the Tender Documents and has satisfied himself by careful examination before submitting his tender as to the nature of the surface, strata, soil, sub-soil and ground, the form and nature of site and local conditions, the quantities, nature and magnitude of the work, the availability of labour and materials necessary for the execution of work, the means of access to SITE, the supply of power and water thereto and the accommodation he may require and has made local and independent enquiries and obtained complete information as to the matters and thing referred to, or implied in the tender documents or having any connection therewith and has considered the nature and extent of all probable and possible situations, delays, hindrances or interferences to or with the execution and completion of the work to be carried out under the CONTRACT, and has examined and considered all other matters, conditions and things and probable and possible contingencies, and generally all matters incidental thereto and ancillary thereof affecting the execution and completion of the WORK and which might have influenced him in making his tender.

C. The Tender Documents including the Notice Letter Inviting Tender, General Conditions of Contract, Special Conditions of Contract, Schedule of Rates, General Obligations, SPECIFICATIONS, DRAWINGS, PLANS, Time Schedule for completion of Jobs, Letter of Acceptance of Tender and any statement of agreed variations with its enclosures copies of which are hereto annexed form part of this CONTRACT though separately set out herein and are included in the expression "CONTRACT" wherever herein used.

AND WHEREAS

The EMPLOYER accepted the Tender of the CONTRACTOR for the provision and the execution of the said WORK at the rates stated in the schedule of quantities of the work and finally approved by EMPLOYER (hereinafter called the "Schedule of Rates") upon the terms and subject to the conditions of CONTRACT.

NOW THIS AGREEMENT WITNESSETH AND IT IS HEREBY AGREED AND DECLARED AS FOLLOWS: -

1. In consideration of the payment to be made to the CONTRACTOR for the WORK to be executed by him, the CONTRACTOR hereby covenants with EMPLOYER that the CONTRACTOR shall and will duly provide, execute and complete the said work and shall do and perform all other acts and things in the CONTRACT mentioned or described or which are to be implied there from or may be reasonably necessary for the completion of the said WORK and at the said times and in the manner and subject to the terms and conditions or stipulations mentioned in the contract.

2. In consideration of the due provision execution and completion of the said WORK, EMPLOYER does hereby agree with the CONTRACTOR that the EMPLOYER will pay to the CONTRACTOR the respective amounts for the WORK actually done by him and approved by the EMPLOYER at the Schedule of Rates and such other sum payable to the CONTRACTOR under provision of CONTRACT, such payment to be made at such time in such manner as provided for in the CONTRACT.

A N D

3. In consideration of the due provision, execution and completion of the said WORK the CONTRACTOR does hereby agree to pay such sums as may be due to the EMPLOYER for the services rendered by the EMPLOYER to the CONTRACTOR, such as power supply, water supply and others as set for in the said CONTRACT and such other sums as may become payable to the EMPLOYER towards the controlled items of consumable materials or towards loss, damage to the EMPLOYER'S equipment, materials construction plant and machinery, such payments to be made at such time and in such manner as is provided in the CONTRACT.

It is specifically and distinctly understood and agreed between the EMPLOYER and the CONTRACTOR that the CONTRACTOR shall have no right, title or interest in the SITE made available by the EMPLOYER for execution of the works or in the building, structures or work executed on the said SITE by the CONTRACTOR or in the goods, articles, materials etc., brought on the said SITE (unless the same specifically belongs to the CONTRACTOR) and the CONTRACTOR shall not have or deemed to have any lien whatsoever charge for unpaid bills will not be entitled to assume or retain possession or control of the SITE or structures and the EMPLOYER shall have an absolute and unfettered right to take full possession of SITE

and to remove the CONTRACTOR, their servants, agents and materials belonging to the CONTRACTOR and lying on the SITE.

The CONTRACTOR shall be allowed to enter upon the SITE for execution of the WORK only as a licensee simpliciter and shall not have any claim, right, title or interest in the SITE or the structures erected thereon and the EMPLOYER shall be entitled to terminate such license at any time without assigning any reason.

The materials including sand, gravel, stone, loose, earth, rock etc., dug up or excavated from the said SITE shall, unless otherwise expressly agreed under this CONTRACT, exclusively belong to the EMPLOYER and the CONTRACTOR shall have no right to claim over the same and such excavation and materials should be disposed of on account of the EMPLOYER according to the instruction in writing issued from time to time by the ENGINEER-IN-CHARGE.

In Witness whereof the parties have executed these presents in the day and the year first above

written.

**Signed and delivered for and on behalf
on behalf of the EMPLOYER**

**Signed and delivered for and on
behalf of the CONTRACTORS.**

GOA NATURAL GAS PRIVATE LIMITED

(NAME OF THE CONTRACTOR)

Place:

Place:

Date:

Date:

IN PRESENCE OF TWO WITNESSES

1. _____

1. _____

2. _____

2. _____

INTEGRITY PACT

INTRODUCTION:

M/s. Goa Natural Gas Pvt. Ltd. (GNGPL), Porvorim, North Goa- 403 521. GNGPL as one of its endeavor to maintain and foster most ethical and corruption free business environment, have decided to adopt the Integrity Pact, a tool developed by the Transparency International, to ensure that all activities and transactions between the Company (GNGPL) and its Counterparties (Bidders, Contractors, Vendors, Suppliers, Service Providers/Consultants etc.) are handled in a fair and transparent manner, completely free of corruption.

Considering the above, the details mentioned **at attached Annexure-1** are applicable as stated in Instruction to Bidders of Bid Document in addition to the existing stipulation regarding Corrupt and Fraudulent Practices.

The attached copy of the **Integrity Pact at Annexure- 2** shall be included in the Bid submitted by the bidder (to be executed by the bidder for all tenders of value Rs. 1 (One) crore and above). In case a bidder does not sign the Integrity Pact, his bid shall be liable for rejection.

Bidder is required to sign the Integrity Pact with GNGPL as per format & terms and conditions enclosed with tender. In case a bidder does not sign the Integrity Pact, his bid shall be liable for rejection.

I COMMITMENTS AND OBLIGATIONS OF THE “COUNTERPARTY”

The Counterparty, directly or indirectly (through agent, consultant, advisor, etc.), shall not pay any bribe/ influence or give undue/ unlawful benefit to anyone to gain undue advantage in dealing with GNGPL.

The Counterparty will not engage in collusion of any kind including price fixation etc. with other Counterparts.

The counterparty will not pass GNGPL’s confidential information to any third party unless specifically authorized by GNGPL in writing.

The Counterparties shall promote and observe best ethical practices within their respective organizations.

The Counterparty shall inform the Independent External Monitor.

- i) If it received any demand, directly or indirectly, for a bribe/ favour or any illegal gratification/ payment / benefit;
- ii) If it comes to know of any unethical or illegal payment / benefit;
- iii) If it makes any payment to any GNGPL associate.

The Counterparty shall not make any false or misleading allegations against GNGPL or its associates.

II VIOLATIONS & CONSEQUENCES:

If a Counterparty commits a violation of its Commitments and Obligations under the Integrity Pact Programme during bidding process, their entire Earnest Money Deposit/ Bid Security, would be forfeited and in addition, they may be blacklisted from the GNGPL business in future.

In case of violation of the Integrity pact by Counterparty after award of the Contract, GNGPL shall be entitled to terminate the Contract. GNGPL would forfeit the security deposits, encash the bank guarantee (s) and other payments payable to Counterparty in such cases, subject to satisfaction of the Independent External Monitor, GNGPL may ban/ blacklist/ put on holiday and exclude the Counterparty from future dealings until GNGPL is satisfied that the Counterparty shall not commit any such violation in future.

In addition to above, GNGPL reserves its right to initiate criminal proceedings against the violating Counterparty, if the allegations by Counterparty are found frivolous, untrue and misleading and may also impose exemplary cost for the same.

The Counterparty will be entitled to claim as determined by the Independent External Monitor, if the above (d) is found incorrect.

INDEPENDENT EXTRNAL MONITORS (IEMS)

The Bidder(s), in case of any dispute(s) / complaint(s) pertaining to this Tender may raise the issue with the designated Tender Issuing Officer in GNGPL.

INTEGRITY PACT

(To be executed on plain paper)

Between GNGPL (Goa Natural Gas Pvt. Ltd. here-in-after referred to as "Principal"). **AND**

_____ (here-in-after referred to as "The Bidder/ Contractor").

(Principal and the Bidder / Contractor are here-in-after are referred to individually as "Party" or collectively as "Parties").

PREAMBLE

The Principal intends to award under laid down organizational procedures, contract/s for _____

The Principal values full compliance with all relevant laws and regulations, and the principles of economic use of resources, and of fairness and transparency in its relations with its Bidder/s and Contractor/s.

In order to achieve these goals, the Principal co-operates with the renowned International Non-Governmental Organisation 'Transparency International' (TI). Following TI's national and international experience, the Principal will appoint an Independent External Monitor who will monitor the tender process, the execution of the contract etc. for compliance with the principles mentioned above.

Section 1 – Commitments of the Principal

1. The Principal commits itself to take all measures necessary to prevent corruption and to observe the following Principles in this regard:-

No employee of the Principal, either in person or through family members, including relatives, will in connection with the tender for or the execution of a contract, demand or accept a promise for or accept for him/herself or for a third person, any material or immaterial benefit to which he/she is not legally entitled.

The Principal shall, during the tender process treat all Bidders with equity. The Principal undertakes and ensures that before and during the tender process shall provide and share the same information to all Bidders and will not provide to any Bidder confidential / additional information through which one particular Bidder could take an advantage in relation to the tender process or the contract execution.

The Principal will exclude from the process all known prejudiced persons.

2. If the Principal obtains information on the conduct of any of its employees which is a criminal offence under the Anti-Corruption Laws of India, or if there be a substantive suspicion in this regard, the Principal will inform its Vigilance Office and in addition can initiate disciplinary actions.

Section 2 – Commitments and Undertakings by the Bidder/Contractor

1. The Bidder / Contractor commits and undertakes to take all measures necessary to prevent malpractices & corruption. He commits himself to observe the following principles during his participation in the tender process and during the contract execution:

The Bidder / Contractor undertakes not to, directly or through any other person or firm offer, promise or give or influence to any employee of the Principal associated with the tender process or the execution of the contract or to any other person on their behalf any material or immaterial benefit to which he / she is not legally entitled in order to obtain in exchange any advantage of any kind whatsoever during the tender process or during the execution of the contract.

The Bidder / Contractor undertakes not to enter into any undisclosed agreement or understanding, whether formal or informal with other Bidders. This applies in particular to prices, specifications, certifications, subsidiary contracts, submission or non-submission of bids or any other action to restrict competitiveness or to introduce cartelization in the bidding process.

The Bidder / Contractor undertakes not to commit any offence under the relevant Anti-corruption Laws of India. Further, the Bidder / Contractor will not use improperly any information or document provided by the Principal as part of the business relationship regarding plans, technical proposals and business details, including information contained or transmitted electronically for the purposes of competition or personal gain and will not pass the information so acquired on to others.

The Bidder / Contractor will, when presenting his bid undertakes to disclose any and all payments made, is committed to or intends to make to agents, brokers or any other intermediaries in connection with the award of the contract.

2. The Bidder / Contractor will not instigate and allure third persons / parties to commit offences outlined above or be an accessory to such offences.

Section 3 – Disqualification from tender process and exclusion from future contracts

If the Bidder, before the award of contract, has committed a transgression through a violation of any provisions of Section 2 or in any other form so as to put his reliability or credibility as Bidder into question, the Principal shall be entitled to disqualify, put on holiday or blacklist the Bidder including from the future tender process or to terminate the contract, if already signed, on that ground.

1. If the Bidder / Contractor has committed a transgression through a violation of any provisions of Section 2 so as to put his reliability or credibility into question, the Principal shall be entitled to exclude including blacklist and put on holiday the Bidder / Contractor from entering into any GNGPL future contract tender processes. The imposition and duration of the exclusion will be determined by the severity of the transgression. The severity will be determined by the Principal taking into consideration the full facts and circumstances of each case particularly taking into account the number of transgressions, the position of the transgressors within the company hierarchy of the Bidder and the amount of the damage. The exclusion may be imposed for a minimum period of 6 months and maximum of three years.

2. A transgression is considered to have occurred if the Principal after due consideration of the available evidence, concludes that no reasonable doubt is possible.
3. The Bidder with its free consent and without any influence agrees and undertakes to respect and uphold the Principal's absolute rights to resort to and impose such exclusion and further accepts and undertakes not to challenge or question such exclusion on any ground, including the lack of any hearing before the decision to resort to such exclusion is taken. This undertaking is given freely and after obtaining independent legal advice.
4. Subject to the full satisfaction of the Principal, the exclusion of the Bidder / Contractor could be revoked by Principal prematurely if the bidder / contractor can prove that he has restored / recouped the damage caused by him and has installed a suitable corruption prevention system in his organization.

Section 4 – Forfeiture of EMD / Security Deposits

1. If the Principal has disqualified the Bidder from the tender process prior to the award in terms of Section 3, and during the execution of the contract, the Principal shall forfeit earnest money deposit / bid security money, encash the bank guarantee including due payments in addition to blacklisting or putting on holiday the bidder and terminating the contract.
2. If the Principal has terminated the contract according to Section 3, or if the Principal is entitled to terminate the contract according to Section 3, the Principal shall be entitled to demand and recover from the Contractor liquidated damages equivalent to Earnest Money Deposit / Security Deposit / Performance Bank Guarantee.

Section 5 – Previous transgression

1. The Bidder swears on oath that no previous transgression has occurred during the last three years with any other Company in any country conforming to the TI approach or including with any other Public Sector Enterprise / Undertaking in India that could justify his exclusion from the tender process.
2. If the Bidder makes incorrect statement on this subject, he shall be disqualified from the tender process or the contract, if already awarded, could be liable to be terminated on this ground.

Section 6 – Equal treatment to all Bidders / Contractors / Subcontractors

1. The Bidder / Contractor undertakes to demand from all its sub-contractors, if any, an undertaking and commitment in conformity with this Integrity Pact, and to submit it to the Principal before signing of the contract.
2. The Principal will enter into agreements with similar conditions, as stipulated herein, with all Bidders, Contractors and Subcontractors.
3. The Principal shall disqualify from the tender process all Bidders who do not sign this Pact or violate any of its provisions.

Section 7 – Criminal charges against violating Bidders / Contractors / Sub-contractors

If the Principal obtains knowledge of conduct of a Bidder, Contractor or Subcontractor, or of an employee or a representative or an associate of a Bidder, Contractor or Subcontractor which constitutes corruption, or if the Principal has substantive suspicion in this regard, the Principal will inform the Vigilance Office / Department for initiating appropriate action for above.

Section 8 –Independent External Monitor / Monitors

1. The Principal appoints competent and credible external independent Monitor for this Pact. The task of the Monitor is to review independently and objectively, whether and to what extent the parties comply with the obligations under this agreement.
2. The Monitor is not subject to any instructions by the representatives of the parties and performs his functions neutrally and independently. He reports to the Chairperson of the Board of the Principal.
3. The Contractor accepts that the Monitor has the right to access without restriction to all Project documentation of the Principal including that provided by the Contractor. The Contractor will also grant the Monitor, upon his request and demonstration of a valid interest, unrestricted and unconditional access to his project documentation. The same is applicable to Sub-contractors. The Monitor is under contractual obligation to treat the information and documents of the Bidder / Contractor / Sub-contractor with confidentiality.
4. The Principal will provide to the Monitor sufficient information about all meetings among the parties related to the Project provided such meetings could have an impact on the contractual relations between the Principal and the Contractor. The parties offer to the Monitor the option to participate in such meetings.
5. As soon as the Monitor notices, or believes to notice, a violation of this agreement he will so inform the Management of the Principal and request the Management to discontinue or heal the violation or to take other relevant action. The monitor can in this regard submit non-binding recommendations. Beyond this, the Monitor has no right to demand from the parties that they act in a specific manner, refrain from action or tolerate action. However, the Independent External Monitor shall give an opportunity to the bidder / contractor to present its case before making its recommendations to the Principal.
6. The Monitor will submit a written report to the Chairperson of the Board of the Principal within 8 to 10 weeks from the date of reference or intimation to him by the 'Principal' and should the occasion arise, submit proposals for taking corrective measures.
7. Monitor shall be entitled to compensation by the Principal.
8. If the Monitor has reported to the Chairperson of the Board a substantiated suspicion of an offence under relevant Anti-Corruption laws of India, and the Chairperson has not, within reasonable time, taken visible action to proceed against such offence or reported it to the Vigilance Office, the Monitor may also transmit this information directly to the Central Vigilance Commissioner, Government of India.

9. The word 'Monitor' would include both singular and plural.
10. Independent External Monitor shall be required to maintain confidentiality of the information acquired and gathered during their tenure / role as Independent Monitor. Any breach in this regard would be subject to the legal judicial system of India.
11. The Independent External Monitors shall be responsible to oversee the implementation of Integrity Pact Program to prevent corruption, bribes or any other unethical practices in the GNGPL. However, Monitor(s) shall be personally and severally be liable for any action or suit brought by Bidder / Contractor / against the Monitor, in case the findings of Independent Monitor is / are found incorrect or biased or prejudiced.
12. Independent External Monitor(s) shall be required to furnish an Undertaking and shall disclose before taking any assignment that he / she has no interest in the matter or connected with the party (bidder / contractor) in any manner.

Section 9 – Pact Duration

The provisions of this Pact shall come into effect from the date of signing of this Pact by the both parties. It expires for the Contractor 12 months after the last payment under the respective contract, and for all other Bidders 6 months after the contract has been awarded.

If any claim is made / lodged by either party during this time, the same shall be binding and continue to be valid despite the lapse of this pact as specified above, unless it is discharged/determined by the Chairperson of the Principal.

Section 10 – Miscellaneous provisions

1. This agreement is subject to Indian Law. Place of performance and jurisdiction is the Registered Office of the Principal, i.e., Goa. The Arbitration clause provided in main tender document / contract shall not be applicable for any issue / dispute arising under Integrity Pact.
2. Changes and supplements as well as termination notices, if any, need to be made in writing. Side agreements have not been made.
3. If the Contractor / Bidder is a partnership concern or a consortium, this agreement must be signed by all partners or consortium members.
4. In case any or several of the provisions of this agreement turn out to be void, the remainder of this pact shall remain valid. The parties to this pact however, shall strive to come to an agreement to their original intentions in such a case.

(Name & Designation)

For the Principal

Place & Date -----

-

(Name & Designation)

For the Bidder/Contractor

Witness1:

Witness2:

**PROCEDURE FOR ACTION IN CASE
CORRUPT/FRAUDULENT/COLLUSIVE/COERCIVE PRACTICES**

A. Definitions:

- A.1 “Corrupt Practice” means the offering, giving, receiving or soliciting, directly or indirectly, anything of value to improperly influence the actions in selection process or in contract execution.
- A.2 “Corrupt Practice” also includes any omission for misrepresentation that may mislead or attempt to mislead so that financial or other benefit may be obtained or an obligation avoided.
- A.3 “Fraudulent Practice” means and include any act or omission committed by a agency or with his connivance or by his agent by misrepresenting/ submitting false documents and/ or false information or concealment of facts or to deceive in order to influence a selection process or during execution of contract/ order.
- A.4 “Collusive Practice amongst bidders (prior to or after bid submission)” means a scheme or arrangement designed to establish bid prices at artificial non-competitive levels and to deprive the Employer of the benefits of free and open competition.
- A.5 “Coercive practice” means impairing or harming or threatening to impair or harm directly or indirectly, any agency or its property to influence the improperly actions of an agency, obstruction of any investigation or auditing of a procurement process.
- A.6 “Vendor/Supplier/Contractor/Consultant/Bidder” is herein after referred as “Agency”
- A.7 “Appellate Authority” shall mean Committee of Directors of Goa Natural Gas Pvt. Ltd.
- A.8 “Competent Authority” shall mean the authority, who is competent to take final decision for Suspension of business dealing with an Agency/ (ies) and Banning of business dealings with Agency/ (ies) and shall be the “CEO”.
- A.9 “Allied Agency” shall mean all the concerns within the sphere of effective influence of banned/ suspended agencies. In determining this, the following factors may be taken into consideration:

B. Actions against bidder(s) indulging corrupt/fraudulent/collusive/coercive practice

B.1. Irregularities noticed during the evaluation of the bids: -

If it is observed during bidding process/ bids evaluation stage that a bidder has indulged in corrupt/fraudulent /collusive/coercive practice, the bid of such Bidder (s) shall be rejected and its Earnest Money Deposit (EMD) shall be forfeited.

Further, such agency shall be banned for future business with Goa Natural Gas Pvt. Ltd. for a period specified in para-B 2.2 below from the date of issue of banning order.

B.2. Irregularities noticed after award of contract: -

i) During execution of contract:

If an agency, is found to have indulged in corrupt/fraudulent/ collusive/coercive practices, during execution of contract, the agency shall be banned for future business with Goa Natural Gas Pvt. Ltd. for a period specified in para-B 2.2 below from the date of issue of banning order.

The concerned order (s)/ contract(s) where corrupt/fraudulent/collusive practices is observed, shall be suspended with immediate effect by Engineer-in-Charge (EIC)/ Employer whereby the supply/ work/ service and payment etc. will be suspended. The action shall be initiated for putting the agency on banning.

After conclusion of process, the order (s)/ contract (s) where it is concluded that such irregularities have been committed shall be terminated and Contract cum Performance Bank Guarantee (CPBG)/ Contract Performance Security (CPS) submitted by agency against such order (s)/ contract (s) shall also be forfeited. The amount that may have become due to the contractor on account of work already executed by him shall be payable to the contractor and this amount shall be subject to adjustment against any amounts due from the contractor under the terms of the contract.

No risk and cost provision will be enforced in such cases.

ii) After execution of contract and during Defect liability period (DLP)/ Warranty/Guarantee Period:

If an agency is found to have indulged in corrupt/fraudulent/ collusive/coercive practices, after execution of contract and during DLP/ Warranty/Guarantee Period, the agency shall be banned for future business with GOA NATURAL GAS PVT. LTD. for a period specified in para B 2.2 below from the date of issue of banning order.

Further, the Contract cum Performance Bank Guarantee (CPBG)/Contract Performance Security (CPS) submitted by agency against such order (s)/ contract (s) shall be forfeited.

(iii) After expiry of Defect liability period (DLP)/ Warranty/Guarantee Period

If an agency is found to have indulged in corrupt/fraudulent/ collusive/coercive practices, after expiry of Defect liability period (DLP)/ Warranty/Guarantee Period, the agency shall be banned for future business with GNGPL a s for a period specified in para-B 2.2 below from the date of issue of banning order.

B.2.2 Period of Banning: -

Banning period shall be reckoned from the date of banning order and shall be as under.

Sl. No	Description	Period of banning from the date of issuance of banning order
1	Misrepresentation/false information other than pertaining to BEC of tender but having impact on selection process. For example, if an agency confirms not being on holiday /banning list of PSU/Govt. Dept., liquidation, bankruptcy etc. and subsequently it is found otherwise, such acts shall be considered in this category	02 years
2	corrupt/coercive practices pertaining to BEC of tender	03 years
2.1	If an agency commits corrupt/coercive practices pertaining to BEC of tender in subsequent cases after their banning, such situation of repeated offence to be dealt with more severity and following shall be period of banning	
(i)	Repeated once	07 years (in addition to the period already served)
(ii)	Repeated twice or more	15 years (in addition to the period already served)
3	Indulged in unauthorized disposal of materials provided by GNGPL	7 years
4	If act of vendor/ contractor is a threat to the National security	15 years
5	Corrupt/Fraudulent/Collusive/Coercive Practices during execution of contract	2 years

In exceptional cases where the act of vendor/ contractor is a threat to the National Security, the banning shall be for indefinite period.

C. Effect of banning on other ongoing contracts/ tenders

- C.1. If an agency is put on Banning, such agency should not be considered in ongoing tenders/future tenders.
- C.2. However, if such an agency is already executing other order (s)/ contract (s) where no corrupt/fraudulent/ collusive/coercive practice is found, the agency should be allowed to continue till its completion without any further increase in scope except those incidental to original scope mentioned in the contract.
- C.3. If an agency is put on the Banning List during tendering and no irregularity is found in the case under process:
 - C.3.1 after issue of the enquiry /bid/tender but before opening of Technical bid, the bid submitted by the agency shall be ignored.
 - C.3.2 after opening Technical bid but before opening the Price bid, the Price bid of the agency shall not be opened and BG/EMD submitted by the agency shall be returned to the agency.
 - C.3.3 after opening of price, BG/EMD made by the agency shall be returned; the offer of the agency shall be ignored & will not be further evaluated. If the agency is put on banning list for fraud/ mis-appropriation of facts committed in the same tender/other tender where errant agency emerges as the lowest (L1), then such tender shall also be cancelled and re-invited.

D. Procedure for Suspension of Bidder

D.1 Initiation of Suspension

Action for suspension business dealing with any agency/(ies) shall be initiated by Corporate C&P Department when

- (i) Corporate Vigilance Department based on the fact of the case gathered during investigation by them recommend for specific immediate action against the agency.
- (ii) Corporate Vigilance Department based on the input from Investigating agency, forward for specific immediate action against the agency.

D.2 Suspension Procedure:

- D.2.1 The order of suspension would operate initially for a period not more than six months and is to be communicated to the agency and also to Corporate Vigilance Department. Period of suspension can be extended with the approval of the Competent Authority by one month at a time with a ceiling of six months pending a conclusive decision to put the agency on banning list.
- D.2.2 During the period of suspension, no new business dealing may be held with the agency.
- D.2.3 Period of suspension shall be accounted for in the final order passed for banning of business with the agency.
- D.2.4 The decision regarding suspension of business dealings should also be communicated to the agency.
- D.2.5 If a prima-facie, case is made out that the agency is guilty on the grounds which can result in banning of business dealings, proposal for issuance of suspension order and show cause notice shall be put up to the Competent Authority. The suspension order and show cause notice must include that

- (i) the agency is put on suspension list and (ii) why action should not be taken for banning the agency for future business from Goa Natural Gas Pvt Ltd.

The competent authority to approve the suspension will be same as that for according approval for banning.

E. Appeal against the Decision of the Competent Authority:

- E.1 The agency may file an appeal against the order of the Competent Authority for putting the agency on banning list. The appeal shall be filed to Appellate-Authority. Such an appeal shall be preferred within one month from the of receipt of banning order.
- E.2 Appellate Authority would consider the appeal and pass appropriate order which shall be communicated to the party as well as the Competent Authority.
- E.3 Appeal process may be completed within 45 days of filing of appeal with the Appellate Authority.

- F. Wherever there is contradiction with respect to terms of 'Integrity pact'. GCC and 'Procedure for action in case of Corrupt/Fraudulent/ Collusive/Coercive Practice', the provisions of 'Procedure for action in case of Corrupt/Fraudulent/ Collusive/Coercive Practice' shall prevail.

**PROCEDURE FOR EVALUATION OF PERFORMANCE OF VENDORS/
SUPPLIERS/CONTRACTORS/ CONSULTANTS**

1.0 OBJECTIVE

The objective of Evaluation of Performance aims to recognize, and develop reliable Vendors/ Suppliers/Contractors/ Consultants so that they consistently meet or exceed expectations and requirements.

The purpose of this procedure is to put in place a system to monitor performance of Vendors/ Suppliers/Contractors/ Consultants associated with Goa Natural Gas Pvt. Ltd. in Projects and in O&M so as to ensure timely completion of various projects, timely receipt of supplies including completion of works & services for operation and maintenance of operating plants and quality standards in all respects.

2.0 METHODOLOGY

- i) Preparation of Performance Rating Data Sheet
Performance rating data Sheet for each and every Vendor/ Supplier/Contractor/ Consultant for all orders/Contracts with a value of Rs. 7 Lakhs and above is recommended to be drawn up. These data sheets are to be separately prepared for orders/ contracts related to Projects and O&M. Format, Parameters, Process, responsibility for preparation of Performance Rating Data Sheet are separately mentioned.
- ii) Measurement of Performance
Based on the parameters defined in Data Sheet, Performance of concerned Vendor/ Supplier/Contractor/ Consultant would be computed and graded accordingly. The measurement of the performance of the Party would be its ability to achieve the minimum scoring of 60% points in the given parameters.
- iii) Initiation of Measures:
Depending upon the Grading of Performance, corrective measures would Be initiated by taking up the matter with concerned Vendor/ Supplier/Contractor/ Consultant. Response of Vendor/ Supplier/Contractor/ Consultant would be considered before deciding further course of action.
- iv) Implementation of Corrective Measures:
Based on the response of Vendor/ Supplier/Contractor/ Consultant, concerned Engineer-in-Charge for the Projects and/or OIC in case of O&M would recommend for continuation or discontinuation of such party from the business of Goa Natural Gas Pvt Ltd
- v) Orders/contracts placed on Proprietary/OEM basis for O&M will be evaluated and, if required, corrective action will be taken for improvement in future.

3.0 PROCESS OF EVALUATION OF PERFORMANCE OF VENDORS/ SUPPLIERS/ CONTRACTORS/ CONSULTANTS

3.1 FOR PROJECTS

- i) Evaluation of performance of Vendors/ Suppliers/Contractors/ Consultants in case of PROJECTS shall be done immediately with commissioning of any Project.
- ii) On commissioning of any Project, EIC (Engineer-in-charge)/ Project-in-charge shall prepare a Performance Rating Data Sheet (Format at Annexure-1) for all Orders and Contracts.
- iii) Depending upon the Performance Rating, following action need to be initiated by Engineer-in-charge/Project-in-charge:

Sl. No.	Performance Rating	Action
1	POOR	Seek explanation for Poor performance
2	FAIR	Seek explanation for Fair performance
3	GOOD	Letter to the concerned for improving performance in future
4	VERY GOOD	No further action

- iv) Reply from concerned Vendor/ Supplier/Contractor/ Consultant shall be examined. In case of satisfactory reply, Performance Rating data Sheet to be closed with a letter to the concerned for improving performance in future.
- v) When no reply is received or reasons indicated are unsatisfactory, the following actions need to be taken:

A Where Performance rating is "POOR":

Recommend such defaulting Vendor/ Supplier/Contractor/ Consultant for putting on Holiday for a period from Six months to three years as given below:

Poor Performance due to reasons other than Quality: **Six Months**

Poor Performance on account of Quality (if any mark obtained against Quality parameter is less than 30): **Six Months**

Poor Performance leading to termination of contract or offloading of contract due to poor performance solely attributable to Vendor/ Supplier/Contractor/ Consultant or Repeated Offence: **Six Months**

In case of repeated offence on above ground covered under sl. no.

(i), (ii) and (iii):

For once- **1 year**.

For two and above-**3 years**

Non-performance of a Vendor/Supplier/Contractor/Consultant leading to termination of Contract/ Order, such Vendor/ Supplier/ Contractor/Consultant are also to be considered for Suspension.

In all such cases, concerned site will put up recommendation for issuance of SCN and putting the party on suspension list as per process defined for suspension in clause no. 5.4 of "Procedure for evaluation of performance of Vendors/Suppliers/Contractors/ Consultants"

B Where Performance rating is "FAIR":

Recommend for issuance of warning to such defaulting Vendor/ Supplier/Contractor/ Consultant to improve their performance.

3.2 FOR CONSULTANCY JOBS

Monitoring and Evaluation of consultancy jobs will be carried out in the same way as described in para 3.1 for Projects.

3.3 FOR OPERATION & MAINTENANCE

- i) Evaluation of performance of Vendors/ Suppliers/Contractors/ Consultants in case of Operation and Maintenance shall be done immediately after execution of order/ contract.
- ii) After execution of orders a Performance Rating Data Sheet (Format at Annexure-2) shall be prepared for Orders by Site C&P and for Contracts/Services by respective Engineer-In-Charge.
- iii) Depending upon Performance Rating, following action need to be initiated by Project-in-charge: -
SAME AS ABOVE CLAUSE 3.1, 3.2, 3.3

4.0 REVIEW & RESTORATION OF PARITES PUT ON HOLIDAY

4.1 An order for Holiday passed for a certain specified period shall deemed to have been automatically revoked on the expiry of that specified period and it will not be necessary to issue a specific formal order of revocation. Further, in case Vendor/ Supplier/Contractor/ Consultant is put on holiday due to quality, and new order is placed on bidder after restoration of Vendor/ Supplier/Contractor/ Consultant, such order will be properly monitored during execution stage by the concerned site.

5.0 EFFECT OF HOLIDAY

5.1 If a Vendor/Supplier/Contractor/Consultant is put on Holiday, such Vendor/Supplier /Contractor/ Consultant should not be considered in ongoing tenders/future tenders.

5.2 However, if such Vendor/ Supplier/Contractor/ Consultant is already executing any other order/ contract and their performance is satisfactory in terms of the relevant contract, should be allowed to continue till its completion without any further increase in scope except those incidental to original scope mentioned in the contract. In such a case CPBG will not be forfeited and payment will be made as per provisions of concerned contract. However, this would be without prejudice to other terms and conditions of the contract.

5.3 Effect on other ongoing tendering:

5.3.1 after issue of the enquiry /bid/tender but before opening of Technical bid, the bid submitted by the party shall be ignored.

5.3.2 after opening Technical bid but before opening the Price bid, the Price bid of the party shall not be opened and BG/EMD submitted by the party shall be returned to the party.

5.3.3 after opening of price, BG/EMD made by the party shall be returned; the offer of the party shall be ignored & will not be further evaluated. If errant party emerges as the lowest (L1), then such tender shall also be cancelled and re- invited.

5.4 Procedure for Suspension of Bidder

5.4.1 Initiation of Suspension

Action for suspension of business dealing with any agency/(ies) shall be initiated by C&P Department when Non-performance of Vendor / Supplier Contractor/ Consultant leading to termination of Contract/ Order.

5.4.2 Suspension Procedure:

5.4.2.1 The suspension period shall be limited to maximum six months.

5.4.2.2 The suspension order shall also be hosted on Goa Natural Gas Pvt. Ltd. intranet and a copy will be forwarded to all OICs/ HODs by C&P Department. During the period of suspension, no new business dealing may be held with the agency.

5.4.2.3 Period of suspension shall be accounted for in the final order passed for putting the party for holiday

5.4.2.4 The decision regarding suspension of business dealings should also be communicated to the agency.

5.4.2.5 Prior to putting the party on holiday, proposal for issuance of suspension order and show cause notice shall be put up to the Competent Authority. The suspension order and show cause notice must include that (i) the agency is put on suspension list and (ii) why

action should not be taken for putting the agency on holiday for future business from Goa Natural Gas Pvt. Ltd..

The competent authority to approve the suspension will be same as that for according approval for holiday.

5.4.2.6 The process for putting the agency on suspension list shall be completed within 30 days from the date of recommendation by site committee.

5.4.3 Effect of Suspension of business:

Effect of suspension on other on-going/future tenders will be as under:

5.4.3.1 No enquiry/bid/tender shall be entertained from an agency as long as the name of Agency appears in the Suspension List.

5.4.3.2 If an agency is put on the Suspension List during tendering:

5.4.3.2.1 after issue of the enquiry /bid/tender but before opening of Technical bid, the bid submitted by the agency shall be ignored.

5.4.3.2.2 after opening Technical bid but before opening the Price bid, the Price bid of the agency shall not be opened and EMD submitted by the agency shall be returned to the agency.

5.4.3.2.3 after opening of price, the offer of the agency shall be ignored & will not be further evaluated. If the agency emerges as the lowest (L1), then such tender shall also be cancelled and reinvited. EMD submitted by such agency shall be returned.

5.4.3.3 The existing contract (s)/ order (s) under execution shall continue.

5.4.3.4 Tenders invited for procurement of goods, works and services shall have provision that the bidder shall submit a undertaking to the effect that (i) neither the bidder themselves nor their allied agency/(ies) are on banning list of Goa Natural Gas Pvt. Ltd. or the Ministry of Petroleum and Natural Gas and (ii) bidder is not banned by any Government department/ Public Sector

6.0 While putting the Vendor/ Supplier/Contractor/ Consultant on holiday as per the procedure, the holding company, subsidiary, joint venture, sister concerns, group division of the errant Vendor/ Supplier/Contractor/ Consultant shall not be considered for putting on holiday list.

Any bidder, put on holiday, will not be allowed to bid through consortium route also in new tender during the period of holiday.

7.0 If an unsuccessful bidder makes any vexatious, frivolous or malicious complaint against the tender process with the intention of delaying or defeating any procurement or causing loss to Goa Natural Gas Pvt. Ltd. or any other bidder, such bidder will be put on holiday for a period of six months, if such complaint is proved to be vexatious, frivolous or malicious, after following the due procedure.

8.0 APPEAL AGAINST THE DECISION OF THE COMPETENT AUTHORITY:

(a) The party may file an appeal against the order of the Competent Authority for putting the party on Holiday list. The appeal shall be filed to Appellate Authority. Such an appeal shall be preferred within one month from the of receipt of Holiday order.

(b) Appellate Authority would consider the appeal and pass appropriate order which shall be communicated to the party as well as the Competent Authority.

(c) Appeal process may be completed within 45 days of filing of appeal with the Appellate Authority.

(d) "Appellate Authority" shall mean Committee of Directors.

9.0 ERRANT BIDDER

In case after price bid opening the lowest evaluated bidder (L1) is not awarded the job for any mistake committed by him in bidding or withdrawal of bid or modification of bid or varying any term in regard thereof leading to re- tendering, Goa Natural Gas Pvt. Ltd. shall forfeit EMD paid by the bidder and such bidders shall be debarred from participation in re-tendering of the same job(s)/item(s). Further, such bidder will be put on holiday for a period of six months after following the due procedure.

10.0 In case CBEC (Central Board of Excise and Customs)/ any equivalent Central Government agency/ State Government agency brings to the notice of Goa Natural Gas Pvt. Ltd. that the Supplier of Goods / Services (Service Provider) has not remitted the amount towards GST (CGST & SGST/UTGST or IGST) collected from Goa Natural Gas Pvt. Ltd. to the government exchequer, , then party will be put on holiday for a period of six months after following the due procedure.

ANNEXURE-A**PERFORMANCE RATING DATA SHEET (FOR PROJECTS/ CONSULTANCY JOBS/O&M)**

- i) Project/Work Centre :
- ii) Order/ Contract No. & date :
- iii) Brief description of Items/ Works/Assignment :
- iv) Order/Contract value (Rs.) :
- v) Name of Vendor/Supplier/ Contractor/ Consultant :
- vi) Contracted delivery/ Completion Schedule Actual :
- vii) delivery/ : Completion date

Performance Parameter	Delivery/ Completion Performance	Quality Performance	Reliability Performance#	Total
Maximum Marks	40	40	20	100
Marks Allocated				

Note:

Remarks (if any)

PERFORMANCE RATING ()**

Note:

(#) Vendor/Supplier/Contractor/Consultant who seek repeated financial assistance or deviation beyond contract payment term or seeking direct payment to the sub- vendor/sub-contractor due to financial constraints, then '0' marks should be allotted against Reliability Performance.

(*) Allocation of marks should be as per enclosed instructions

(**) Performance rating shall be classified as under:

Sl. No.	Range (Marks)	Rating
1	60 & below	POOR
2	61-75	FAIR
3	76-90	GOOD
4	More than 90	VERY GOOD

*** Instructions for allocation of marks**

1.1 DELIVERY/COMPLETION PERFORMANCE (40 marks)

Delivery period/completion schedule	Delay in weeks	Marks
1) up to 03 months	Before CDD	40
	Delay up to 4 weeks	35
	8 weeks	30
	10 weeks	25
	12 weeks	20
	16 weeks	15
	More than 16 weeks	0
2) above 03 months	Before CDD	40
	Delay up to 4 weeks	35
	8 weeks	30
	10 weeks	25
	16 weeks	20
	20 weeks	15
	24 weeks	10
	More than 24 weeks	0

1.2 QUALITY PERFORMANCE (40 marks)

A	For normal cases: - No defects/No deviation/no failure	40 marks
B	Rejection/Defects	
1	Marks to be allocated on pro rata basis for acceptance quantity as compared to total quantity for normal cases	10 marks
C	When quality failure endangers system integration and safety of the system	
1	Failure of severe nature	0 marks
2	Moderate nature	5 marks
3	Low severe nature	10-20 marks
D	No. of deviations	
1	No deviation	5 marks
2	Deviations<2	2 marks
3	Deviations>2	0 marks

1.3 RELIABILITY PERFORMANCE (20 marks)

A	FOR WORKS/CONTRACT	
1	Submission of order acceptance, agreement, PBG, drawings and other document on time	4 marks
2	Mobilization of resources as per contract and in time	4 marks
3	Liquidation of check list points	4 marks
4	Compliance to statutory and HS&E requirements or reliability of estimates/design/drawings etc. in case of consultancy jobs	4 marks
5	Timely submission of estimates and other documents for Extra, Substituted & AHR items	4 marks
B	FOR SUPPLIES	
1	Submission of order acceptance, agreement, PBG, drawings and other document on time	5 marks
2	Attending complaints and requests for after sales/service/warranty repairs or query/advice (up to evaluation period)	5 marks
3	Response to various correspondence and conformance to other standards like ISO	5 marks
4	Submission of all required documents including test certificates at the time of supply	5 marks

SECTION – VI: SCHEDULE OF RATE

SUBJECT: HIRING OF OPERATIONS & MAINTENANCE SERVICES FOR CGD PROJECT OF GNGPL IN NORTH GOA GA

ITEM No.	DESCRIPTION OF SERVICES/ACTIVITY/WORK	UOM (UNITS)	QUANTITY	Unit Rate inclusive of all applicable taxes, duties & other levies [if any] payable by the Contractor under the Contract, or for any other cause except final GST in INR	Total Amount inclusive of all applicable taxes & duties & other levies [if any] payable by the Contractor under the Contract, or for any other cause except final GST in INR
1	Hiring of Earth Moving Equipment (JCB)	Hour	50		
2	Hiring of RCC / Rock Breakers	Hour	50		
3	Hiring of Tractor Mounted Air Compressor	Hour	50		
4	Hiring of Generator set (Diesel / Petrol - 30 KVA)	Day	20		
5	Finding & Repairing MDPE Pipeline damages (Without Excavation, Backfilling & Restoration) in Gasified Area				
5.1	20 -32mm MDPE Pipeline	Nos	10		
5.2	63 -90mm MDPE Pipeline	Nos	20		

5.3	125 mm MDPE Pipeline	Nos	20		
6	Finding & Repairing MDPE Pipeline damages (With Excavation, Backfilling & Restoration) in Gasified Area				
6.1	20 -32mm MDPE Pipeline	Nos	10		
6.2	63 -90 mm MDPE Pipeline	Nos	20		
6.3	125 mm MDPE Pipeline	Nos	20		
7	Finding & Repairing MDPE Pipeline damages (Without Excavation, Backfilling & Restoration) in Non-Gasified Area				
7.1	20 -32mm MDPE Pipeline	Nos	20		
7.2	63 -90 mm MDPE Pipeline	Nos	10		
7.3	125 mm MDPE Pipeline	Nos	5		
8	Finding & Repairing MDPE Pipeline damages (With Excavation, Backfilling & Restoration) in Non-Gasified Area				
8.1	20 -32mm MDPE Pipeline	Nos	40		
8.2	63 -90 mm MDPE Pipeline	Nos	20		
8.3	125 mm MDPE Pipeline	Nos	20		
9	Laying of MDPE Pipelines in all type of soil- Open Cut /Moiling Method				
9.1	20 mm - 63 mm MDPE Pipeline	Meters	2000		
9.2	90 mm - 125 mm MDPE Pipeline	Meters	1000		

10	Laying of MDPE Pipelines - HDD Method without Casing in all type of soil				
10.1	20 mm - 63 mm MDPE Pipeline	Meters	800		
10.2	90 mm - 125 mm MDPE Pipeline	Meters	800		
11	Laying of MDPE Pipelines - HDD Method without Casing in hard ground strata / sedimentary rock etc.				
11.1	20 mm - 63 mm MDPE Pipeline	Meters	450		
11.2	90 mm - 125 mm MDPE Pipeline	Meters	450		
12	Excavation and Restoration of Pits/Trenches				
12.1	Restoration of concrete surface by providing RCC M25 grade with 20mm and downgrade crushed stone aggregate as per design. Item includes all material, manpower, shuttering, curing etc. Complete. The steel to be used shall be paid extra as per below SOR (12.2) rate.	Cu. Meters	40		
12.2	Reinforcement Steel :- Supply and fabrication and fixing in position HYSD steel reinforcement/TMT grade Fe-415 confirming to ISI 786-1985 at all level and positions including the cost of transport, straightening, cutting, bending, cranking, binding, welding, provision of necessary chairs and spacers. Preparation of bar bending schedule and getting the same approved by EIC etc. Complete as per drawing and specifications and including cost of binding wire, labour etc. as per the scope of work. The chairs and spacers bars provided will not be measured for payment.	MT	0.5		
	NOTE:- Rate to include all labour, tools, tackles, equipment hire charges, supply of all materials, shuttering, staging, shoring/strutting, finishing, supplying and fixing MS inserts, bolts, testing etc.				

12.3	Providing PCC 1:4:8 for restoration or any other purpose including shuttering, compaction and curing etc. complete,	Cu. Meters	40		
12.4	Restoration of road surface by providing 25mm thick Bitumen carpeting over 50mm thick BM. The surface shall be prepared by putting soiling etc and compacted to received BM and BC. The restoration shall be done to the full satisfaction of local authority. The area shall be measured (width of trench x length) for payment.	Sq. Meters	50		
12.5	Excavation in all type of soil by manual or mechanical means up to depth of 2.0M with back filling, watering, compaction and cleaning of the area complete.	Cu. Meters	50		
13	Installation of New service regulator				
13.1	Installation of New all type of service regulator with required fittings, tools and tackles etc. Regulator is free issue material and remaining all material / fittings/manpower etc is in scope of this item.	Nos	5		
14	Shifting service regulator				
14.1	Shifting of all type of service regulator from existing location to new location with required fittings, tools and tackles.	Nos	6		
15	Fabrication & Erection of New Valve Chamber along with heavy duty RCC cover of required size and as per drawing with all material, manpower etc but cost of valve is not included.				
15.1	Size: 1 m (L) X 1 m (W) X1.5 m (D)	Nos	6		
15.2	Size: 0.6 m (L) X 0.6 m (W) X 1.5 m (D)	Nos	10		
15.3	Fabrication of heavy-duty valve Chamber Cover (new) of existing valve chambers of all sizes with M25 Grade RCC. The drawings of the covers shall be providing based on-site requirement. Item includes supply and placing cover at site after removing existing	Nos	20		

	one. The price shall be for complete chamber which may contain more than one cover.				
15.4	Repair / Modification in size of Valve Chambers - All Sizes	Nos	10		
16	Supply and Installation of New Pipeline Markers				
16.1	RCC Markers	Nos	100		
16.2	Plate marker	Nos	200		
16.3	Steel Pole Markers	Nos	15		
17	Repairing & Reinstallation of Pipeline Markers				
17.1	RCC Markers including grouting with 1:2:4 cement concrete.30x30x40cm.	Nos	50		
17.2	Steel Pole Markers including grouting with 1:2:4 cement concrete 45x45x60CM	Nos	10		
18	Painting and Stenciling of Markers/DRS/MRS/Fencing/Pipeline with sanding, Touch-up Putty wherever required, Painting one coat primer, Surface & Two coats Spray Paint Epoxy or Duco.				
18.1	RCC Markers	Nos	100		
18.2	Steel Pole Markers	Nos	50		
18.3	GI Pipes ½ / ¾, / 1'	Meter	100		
18.4	Valve Chambers	Sq.Meters	50		

18.5	Box Type MRS/DRS	Sq.Meters	200		
18.6	Wall Mounted MRS	Sq.Meters	100		
18.7	Chain link Fencing	Sq.Meters	100		
18.8	MS Pipe of 4"/6"/8'	Sq.Meters	50		
19	Earthing Maintenance work				
19.1	Supply and Installation of chamber cover plate of size(400mmx400mm)	Nos	10		
19.2	25 kg Earthing compound bag	Nos	10		
19.3	Rod (Earthing copper bonded 17.2mm-3 mtr length)	Meter	30		
19.4	Supply and Installation of GI Strep 25x6 mm	Meter	80		
19.5	Repair of Chamber of existing Earthing Pit.	Cu. Meter	10		
20	Supply & Installation, Testing & Commissioning of C class GI pipes of approved make with painting/powder coated. This item shall be mostly used to take PNG connection from existing GI infra, however in case piping to be done to new house/building shall be done with same rate. Item includes all GI fittings of approved make, clamps, petzel and all tools, tackles, manpower complete.				
20.1	1/2 Inch	Meters	500		
20.2	3/4 Inch	Meters	200		

21	Domestic PNG connection				
21.1	Fixing of Meter with or without regulator for PNG consumers with all necessary fitting and fixture required. Meter and regulators are Free issue material.	Nos	200		
21.2	Providing, Fixing and Testing 12mm diameter and 0.6mm thick copper pipe which shall be connected to meter and appliance valve for PNG customer. Item include clamping of the pipe to wall, brazing, bending of the pipe with proper bending die etc. complete,	Meters	200		
21.3	Providing & fixing Appliance valves for domestic PNG connection of approved make	Nos	200		
21.4	Providing & Fixing Isolation valve for Domestic PNG connection of approved make	Nos	200		
22	Fixing and testing of old GI pipe with clamps at all levels				
22.1	1/2 Inch	Meters	100		
22.2	3/4 Inch	Meters	50		
23	Calibration of All Gauges & SRV to be maintained by the contractor (DRS/MRS/ODOURIZING UNIT/CNG COMPRESSOR/ S CASCADE/ M CASCADE)	Nos	100		
24	MDPE Valve & Valve Chamber Operation, maintenance & House Keeping on quarterly basis	Nos	200		
25	House Keeping of DRS / MRS on qtrly basis	Nos	50		
26	Dismantling of GI Pipes - All Sizes	Meters	100		

27	Conversion to start the supply to customer with changing the LPG stove nozzles of all make. The jobs need to be done by skill person with all tools and tackles. The surksha hose needs to be changed as per requirement. If surksha hose is required to be changed than payment of same shall be paid through separate item in SOR. The item includes filling the conversion form and taking signature of the customer after taking initial reading of the meter etc. The rate quoted by the party shall be applicable for North Goa and Ponda and shall be inclusive of all material, manpower as well as transportation etc	Nos	1000		
28	Re-installation of Copper Pipes - With Old Pipes	Meters	100		
29	Dismantling of Copper Pipes	Meters	100		
30	Supply & Providing of GI sleeves with pedestal as per specification.	Nos	20		
31	Supply of Suraksha hose confirming to IS 9573 Type-4 with clamps and nozzles - For conversion to PNG	Meters	200		
32	Supply of Un-Skilled Manpower as and when required basis. The rate shall be for 8 hrs. duty basis.	Man-Days	50		
33	Patrolling of the pipelines (Steel + MDPE) laid by GNGPL along with pipeline route on 2-wheeler fitted with GPS to ensure no unauthorized third party digging along GNGPL network. A report needs to be developed on daily basis regarding any activity noticed along GNGPL network on daily basis. The item included manpower, 2-wheeler along with GPS, fuel etc. The item shall be paid on per KM basis.	Km	100000		
34	Hiring office space for O&M office under North Goa GA Preferably in Old Goa & Corlim. (Carpet area of approx. 1000sft): Carpet area of the office shall be approx. 1000sft with one cabin, 04 cubicle, 04 work station, reception with visitor				

	area, store, 02washroom etc with furniture, adequate number of tables and chairs, desktop, printer, rack for material storage & keeping documents, white board, notice board and parking space for two four - wheelers and three two - wheelers. Item includes monthly maintenance charges, electricity bill, internet, landline phone bill and housekeeping charges etc. For detailed spec please refer detail scope of work for this particular item.				
34.1	1st Year	Months	12		
35	Hiring of Maintenance Van for Operation and Maintenance of various activities of O&M Office.				
35.1	Deployment of maintenance vehicle: (four-wheeler- Mahendran Bolero Camper or equivalent for 24 hours services including driver, fuel, insurance, RTO, consumables and maintenance for free run of 2500 Km per month) including critical equipment's and tools etc. Vehicle shall not be older than 01 years at the time of deployment and it will be customized as per the requirement of O&M office as per design and drawing given in details scope of work.	Per Month	12		
35.2	Charges for extra per Km beyond 2500 km in a month	Km	3000		
36	Making hole for GI/Copper piping				
	Core cutting in RCC, Brick wall, Granite etc of required dia and depth for providing GI piping/ MDPE piping etc with all necessary machine and Manpower etc complete.				
36.1	Up to 50mm dia with all depth in RCC, BW, slab, chajja etc	Nos	300		
36.2	Above 50mm dia with all depth in RCC slab, chajja BW etc	Nos	300		

36.3	In kitchen slab up to 25mm dia in granite, Marble, RCC etc	Nos	300		
37	Providing and fixing MDPE valves of approved make				
37.1	32mm	Nos	5		
37.2	63mm	Nos	5		
37.3	90mm	Nos	5		
37.4	125mm	Nos	5		
38	Flushing & Nitrogen Purging, testing and commissioning of PE network. This item includes flushing the PE network (already Laid) with compressed air. Testing the network by holding pressure of 7 bar for 24 hrs. If there is drop in pressure, contractor is required to identify the leakage points and repair and make report. The cost of repairing is to be included in the item. Filling the PE network with Nitrogen (99% purity) holding the pressure up to 2 BAR for period of 4 hrs.				
38.1	32mm	Meters	200		
38.2	63mm	Meters	2000		
38.3	90mm	Meters	2000		
38.4	125mm	Meters	2000		
39	Shifting of Field Regulating Stations, Meter regulating Skids, Pressure regulating skids Includes Disconnection, Loading, Transportation, of PRS/DRS / FRS/ MRS from GNGPL's designated store / site to another site and all other necessary documentation. Also includes unloading of the regulating				

	systems, skids on the platform / foundation, using cranes / hydra as required by the site conditions.				
39.1	Shifting of MRS/DRS with flow range capacity up to and including 750 SCM _H	Nos	5		
39.2	Shifting of MRS/DRS with flow range capacity above 750 SCM _H	Nos	5		
40	Providing services for O&M office in North Goa GA as per the details given in specification/SCC	Months	12		
Amount Excl. GST					
GST 18%					
Total Amount Incl. GST					
Total Amount including GST (in words): -					
Name of the Bidder:					
Sign & stamp of Authorised Signatory:				Place:	
Name:				Date:	

NOTE:-

1. Bidder to quote prices for all items in each column (i.e., Unit & Total price) and ensure that total prices quoted is for complete scope and terms and conditions of Tender document.
2. Bidder shall quote prices in the given format of Schedule of Rates and shall not modify the format in any form.
3. In case of discrepancy between unit price and total, the unit price shall prevail.
4. Bidder to clearly indicate 'Quoted' / 'Not Quoted' against each Sr. No. in the price column in the un-priced Schedule of Rates and submit the same in Un-priced part of the bid. Bidders to submit Price part of above Schedule of Rates in their Priced Bid.
5. Bidder shall quote prices in the given format of Schedule of Rates and shall not modify the format in any form.

END OF BID DOCUMENT